

LETTER OF TRANSMITTAL

124 Grove Street
Suite 300
Franklin, MA 02038-3156
www.geiconsultants.com

To: Conservation Commission	Date: April 27, 2022
253 Atlantic Avenue	Project No: 1900027
Hull, MA 02045	Re: Town of Hull
	Nantasket Avenue Restoration project

We are sending you the following enclosures:

Quantity	Date	Description
1	4/27/22	Complete NOI Application
1	4/27/22	Full size set of Drawings

These are transmitted as checked below:

For Approval For Your Use For Review/Comment As Requested Other

Message:

Copy to: See Distribution List

Signed: Alyssa Richard

If enclosures are not as noted, kindly notify us at once.



Massachusetts Department of Environmental Protection
Bureau of Resource Protection - Wetlands

WPA Form 3 – Notice of Intent

Massachusetts Wetlands Protection Act M.G.L. c. 131, §40

Provided by MassDEP:

MassDEP File Number

Document Transaction Number

Hull

City/Town

Important:

When filling out forms on the computer, use only the tab key to move your cursor - do not use the return key.



Note: Before completing this form consult your local Conservation Commission regarding any municipal bylaw or ordinance.

A. General Information

1. Project Location (**Note:** electronic filers will click on button to locate project site):

<u>Nantasket Ave</u>	<u>Hull</u>	<u>02045</u>
a. Street Address	b. City/Town	c. Zip Code
Latitude and Longitude:		
<u>8 & 9</u>	<u>42° 18'33.4"N</u>	<u>70°53'27.0"W</u>
f. Assessors Map/Plat Number	d. Latitude	e. Longitude
	<u>various</u>	
	g. Parcel /Lot Number	

2. Applicant:

<u>Philip E.</u>	<u>Lemnios</u>	
a. First Name	b. Last Name	
<u>Town of Hull</u>		
c. Organization		
<u>253 Atlantic Avenue</u>		
d. Street Address		
<u>Hull</u>	<u>MA</u>	<u>02045</u>
e. City/Town	f. State	g. Zip Code
<u>(781) 925-2000</u>	<u>plemnios@town.hull.ma.us</u>	
h. Phone Number	i. Fax Number	j. Email Address

3. Property owner (required if different from applicant): Check if more than one owner

<u></u>	<u></u>	
a. First Name	b. Last Name	
<u></u>		
c. Organization		
<u></u>		
d. Street Address		
<u></u>	<u></u>	<u></u>
e. City/Town	f. State	g. Zip Code
<u></u>	<u></u>	<u></u>
h. Phone Number	i. Fax Number	j. Email address

4. Representative (if any):

<u>Russell</u>	<u>Titmuss</u>	
a. First Name	b. Last Name	
<u>GEI Consultants, Inc</u>		
c. Company		
<u>124 Grove Street, Suite 300</u>		
d. Street Address		
<u>Franklin</u>	<u>MA</u>	<u>02038</u>
e. City/Town	f. State	g. Zip Code
<u>774-277-6003</u>	<u>rtitmuss@geiconsultants.com</u>	
h. Phone Number	i. Fax Number	j. Email address

5. Total WPA Fee Paid (from NOI Wetland Fee Transmittal Form):

<u>Exempt</u>	<u>Exempt</u>	<u>Exempt</u>
a. Total Fee Paid	b. State Fee Paid	c. City/Town Fee Paid



Massachusetts Department of Environmental Protection
Bureau of Resource Protection - Wetlands

WPA Form 3 – Notice of Intent

Massachusetts Wetlands Protection Act M.G.L. c. 131, §40

Provided by MassDEP:
MassDEP File Number
Document Transaction Number
Hull
City/Town

A. General Information (continued)

6. General Project Description:

The Town of Hull proposes to replace and upgrade the shoreline protection structures along Nantasket Avenue within the limits shown on the attached plans. These structures protect portions of Fitzpatrick Way and Nantasket Avenue.

7a. Project Type Checklist: (Limited Project Types see Section A. 7b.)

- 1. Single Family Home
- 2. Residential Subdivision
- 3. Commercial/Industrial
- 4. Dock/Pier
- 5. Utilities
- 6. Coastal engineering Structure
- 7. Agriculture (e.g., cranberries, forestry)
- 8. Transportation
- 9. Other

7b. Is any portion of the proposed activity eligible to be treated as a limited project (including Ecological Restoration Limited Project) subject to 310 CMR 10.24 (coastal) or 310 CMR 10.53 (inland)?

- 1. Yes No If yes, describe which limited project applies to this project. (See 310 CMR 10.24 and 10.53 for a complete list and description of limited project types)

2. Limited Project Type

If the proposed activity is eligible to be treated as an Ecological Restoration Limited Project (310 CMR10.24(8), 310 CMR 10.53(4)), complete and attach Appendix A: Ecological Restoration Limited Project Checklist and Signed Certification.

8. Property recorded at the Registry of Deeds for:

_____	_____
a. County	b. Certificate # (if registered land)
_____	_____
c. Book	d. Page Number

B. Buffer Zone & Resource Area Impacts (temporary & permanent)

- 1. Buffer Zone Only – Check if the project is located only in the Buffer Zone of a Bordering Vegetated Wetland, Inland Bank, or Coastal Resource Area.
- 2. Inland Resource Areas (see 310 CMR 10.54-10.58; if not applicable, go to Section B.3, Coastal Resource Areas).

Check all that apply below. Attach narrative and any supporting documentation describing how the project will meet all performance standards for each of the resource areas altered, including standards requiring consideration of alternative project design or location.



Massachusetts Department of Environmental Protection
Bureau of Resource Protection - Wetlands

WPA Form 3 – Notice of Intent

Massachusetts Wetlands Protection Act M.G.L. c. 131, §40

Provided by MassDEP:
MassDEP File Number
Document Transaction Number
Hull
City/Town

B. Buffer Zone & Resource Area Impacts (temporary & permanent) (cont'd)

For all projects affecting other Resource Areas, please attach a narrative explaining how the resource area was delineated.

Resource Area	Size of Proposed Alteration	Proposed Replacement (if any)
a. <input type="checkbox"/> Bank	1. linear feet	2. linear feet
b. <input type="checkbox"/> Bordering Vegetated Wetland	1. square feet	2. square feet
c. <input type="checkbox"/> Land Under Waterbodies and Waterways	1. square feet	2. square feet
	3. cubic yards dredged	

Resource Area	Size of Proposed Alteration	Proposed Replacement (if any)
d. <input type="checkbox"/> Bordering Land Subject to Flooding	1. square feet	2. square feet
	3. cubic feet of flood storage lost	4. cubic feet replaced
e. <input type="checkbox"/> Isolated Land Subject to Flooding	1. square feet	
	2. cubic feet of flood storage lost	3. cubic feet replaced
f. <input type="checkbox"/> Riverfront Area	1. Name of Waterway (if available) - specify coastal or inland	

2. Width of Riverfront Area (check one):

- 25 ft. - Designated Densely Developed Areas only
- 100 ft. - New agricultural projects only
- 200 ft. - All other projects

3. Total area of Riverfront Area on the site of the proposed project: _____ square feet

4. Proposed alteration of the Riverfront Area:

a. total square feet	b. square feet within 100 ft.	c. square feet between 100 ft. and 200 ft.
----------------------	-------------------------------	--

5. Has an alternatives analysis been done and is it attached to this NOI? Yes No

6. Was the lot where the activity is proposed created prior to August 1, 1996? Yes No

3. Coastal Resource Areas: (See 310 CMR 10.25-10.35)

Note: for coastal riverfront areas, please complete **Section B.2.f.** above.



Massachusetts Department of Environmental Protection
 Bureau of Resource Protection - Wetlands

WPA Form 3 – Notice of Intent

Massachusetts Wetlands Protection Act M.G.L. c. 131, §40

Provided by MassDEP:

MassDEP File Number

Document Transaction Number

Hull

City/Town

B. Buffer Zone & Resource Area Impacts (temporary & permanent) (cont'd)

Check all that apply below. Attach narrative and supporting documentation describing how the project will meet all performance standards for each of the resource areas altered, including standards requiring consideration of alternative project design or location.

Online Users:
 Include your document transaction number (provided on your receipt page) with all supplementary information you submit to the Department.

<u>Resource Area</u>	<u>Size of Proposed Alteration</u>	<u>Proposed Replacement (if any)</u>
a. <input type="checkbox"/> Designated Port Areas	Indicate size under Land Under the Ocean, below	
b. <input type="checkbox"/> Land Under the Ocean	_____	
	1. square feet	

	2. cubic yards dredged	
c. <input checked="" type="checkbox"/> Barrier Beach	Indicate size under Coastal Beaches and/or Coastal Dunes below	
d. <input checked="" type="checkbox"/> Coastal Beaches	<u>13,950 incl. 1,050 CY dredging</u>	<u>up to 900 CY annually</u>
	1. square feet	2. cubic yards beach nourishment
e. <input checked="" type="checkbox"/> Coastal Dunes	<u>82,350</u>	
	1. square feet	2. cubic yards dune nourishment

	<u>Size of Proposed Alteration</u>	<u>Proposed Replacement (if any)</u>
f. <input type="checkbox"/> Coastal Banks	_____	
	1. linear feet	
g. <input checked="" type="checkbox"/> Rocky Intertidal Shores	<u>1,150</u>	
	1. square feet	
h. <input type="checkbox"/> Salt Marshes	_____	
	1. square feet	2. sq ft restoration, rehab., creation
i. <input type="checkbox"/> Land Under Salt Ponds	_____	
	1. square feet	

	2. cubic yards dredged	
j. <input checked="" type="checkbox"/> Land Containing Shellfish	<u>1,150</u>	
	1. square feet	
k. <input type="checkbox"/> Fish Runs	Indicate size under Coastal Banks, inland Bank, Land Under the Ocean, and/or inland Land Under Waterbodies and Waterways, above	

	1. cubic yards dredged	
l. <input checked="" type="checkbox"/> Land Subject to Coastal Storm Flowage	<u>2.2 acres</u>	
	1. square feet	

4. Restoration/Enhancement
 If the project is for the purpose of restoring or enhancing a wetland resource area in addition to the square footage that has been entered in Section B.2.b or B.3.h above, please enter the additional amount here.

_____ a. square feet of BVW _____ b. square feet of Salt Marsh

5. Project Involves Stream Crossings

_____ a. number of new stream crossings _____ b. number of replacement stream crossings



Massachusetts Department of Environmental Protection
Bureau of Resource Protection - Wetlands

WPA Form 3 – Notice of Intent

Massachusetts Wetlands Protection Act M.G.L. c. 131, §40

Provided by MassDEP:	
MassDEP File Number	_____
Document Transaction Number	_____
Hull	_____
City/Town	_____

C. Other Applicable Standards and Requirements

- This is a proposal for an Ecological Restoration Limited Project. Skip Section C and complete Appendix A: Ecological Restoration Limited Project Checklists – Required Actions (310 CMR 10.11).

Streamlined Massachusetts Endangered Species Act/Wetlands Protection Act Review

- Is any portion of the proposed project located in **Estimated Habitat of Rare Wildlife** as indicated on the most recent Estimated Habitat Map of State-Listed Rare Wetland Wildlife published by the Natural Heritage and Endangered Species Program (NHESP)? To view habitat maps, see the *Massachusetts Natural Heritage Atlas* or go to http://maps.massgis.state.ma.us/PRI_EST_HAB/viewer.htm.

- a. Yes No **If yes, include proof of mailing or hand delivery of NOI to:**

**Natural Heritage and Endangered Species Program
Division of Fisheries and Wildlife
1 Rabbit Hill Road
Westborough, MA 01581**

b. Date of map _____

If yes, the project is also subject to Massachusetts Endangered Species Act (MESA) review (321 CMR 10.18). To qualify for a streamlined, 30-day, MESA/Wetlands Protection Act review, please complete Section C.1.c, and include requested materials with this Notice of Intent (NOI); *OR* complete Section C.2.f, if applicable. *If MESA supplemental information is not included with the NOI, by completing Section 1 of this form, the NHESP will require a separate MESA filing which may take up to 90 days to review (unless noted exceptions in Section 2 apply, see below).*

- c. Submit Supplemental Information for Endangered Species Review*

- Percentage/acreage of property to be altered:
 - (a) within wetland Resource Area _____ percentage/acreage
 - (b) outside Resource Area _____ percentage/acreage

- Assessor's Map or right-of-way plan of site

- Project plans for entire project site, including wetland resource areas and areas outside of wetlands jurisdiction, showing existing and proposed conditions, existing and proposed tree/vegetation clearing line, and clearly demarcated limits of work **
 - (a) Project description (including description of impacts outside of wetland resource area & buffer zone)
 - (b) Photographs representative of the site

* Some projects **not** in Estimated Habitat may be located in Priority Habitat, and require NHESP review (see <https://www.mass.gov/endangered-species-act-mesa-regulatory-review>).

Priority Habitat includes habitat for state-listed plants and strictly upland species not protected by the Wetlands Protection Act.

** MESA projects may not be segmented (321 CMR 10.16). The applicant must disclose full development plans even if such plans are not required as part of the Notice of Intent process.



Massachusetts Department of Environmental Protection
Bureau of Resource Protection - Wetlands

WPA Form 3 – Notice of Intent

Massachusetts Wetlands Protection Act M.G.L. c. 131, §40

Provided by MassDEP:	
MassDEP File Number	
Document Transaction Number	
Hull	
City/Town	

C. Other Applicable Standards and Requirements (cont'd)

(c) MESA filing fee (fee information available at <https://www.mass.gov/how-to/how-to-file-for-a-mesa-project-review>).
 Make check payable to "Commonwealth of Massachusetts - NHESP" and **mail to NHESP** at above address

Projects altering 10 or more acres of land, also submit:

- (d) Vegetation cover type map of site
- (e) Project plans showing Priority & Estimated Habitat boundaries
- (f) OR Check One of the Following

1. Project is exempt from MESA review.
 Attach applicant letter indicating which MESA exemption applies. (See 321 CMR 10.14, <https://www.mass.gov/service-details/exemptions-from-review-for-projectsactivities-in-priority-habitat>; the NOI must still be sent to NHESP if the project is within estimated habitat pursuant to 310 CMR 10.37 and 10.59.)

2. Separate MESA review ongoing. _____ a. NHESP Tracking # _____ b. Date submitted to NHESP

3. Separate MESA review completed.
 Include copy of NHESP "no Take" determination or valid Conservation & Management Permit with approved plan.

3. For coastal projects only, is any portion of the proposed project located below the mean high water line or in a fish run?
- a. Not applicable – project is in inland resource area only b. Yes No

If yes, include proof of mailing, hand delivery, or electronic delivery of NOI to either:

South Shore - Cohasset to Rhode Island border, and the Cape & Islands:

North Shore - Hull to New Hampshire border:

Division of Marine Fisheries -
 Southeast Marine Fisheries Station
 Attn: Environmental Reviewer
 836 South Rodney French Blvd.
 New Bedford, MA 02744
 Email: dmf.envreview-south@mass.gov

Division of Marine Fisheries -
 North Shore Office
 Attn: Environmental Reviewer
 30 Emerson Avenue
 Gloucester, MA 01930
 Email: dmf.envreview-north@mass.gov

Also if yes, the project may require a Chapter 91 license. For coastal towns in the Northeast Region, please contact MassDEP's Boston Office. For coastal towns in the Southeast Region, please contact MassDEP's Southeast Regional Office.

- c. Is this an aquaculture project? d. Yes No

If yes, include a copy of the Division of Marine Fisheries Certification Letter (M.G.L. c. 130, § 57).



Massachusetts Department of Environmental Protection
Bureau of Resource Protection - Wetlands

WPA Form 3 – Notice of Intent

Massachusetts Wetlands Protection Act M.G.L. c. 131, §40

Provided by MassDEP:

MassDEP File Number

Document Transaction Number

Hull

City/Town

C. Other Applicable Standards and Requirements (cont'd)

Online Users:
Include your document transaction number (provided on your receipt page) with all supplementary information you submit to the Department.

- 4. Is any portion of the proposed project within an Area of Critical Environmental Concern (ACEC)?
 a. Yes No If yes, provide name of ACEC (see instructions to WPA Form 3 or MassDEP Website for ACEC locations). **Note:** electronic filers click on Website.
 b. ACEC

- 5. Is any portion of the proposed project within an area designated as an Outstanding Resource Water (ORW) as designated in the Massachusetts Surface Water Quality Standards, 314 CMR 4.00?
 a. Yes No
- 6. Is any portion of the site subject to a Wetlands Restriction Order under the Inland Wetlands Restriction Act (M.G.L. c. 131, § 40A) or the Coastal Wetlands Restriction Act (M.G.L. c. 130, § 105)?
 a. Yes No
- 7. Is this project subject to provisions of the MassDEP Stormwater Management Standards?
 a. Yes. Attach a copy of the Stormwater Report as required by the Stormwater Management Standards per 310 CMR 10.05(6)(k)-(q) and check if:
 - 1. Applying for Low Impact Development (LID) site design credits (as described in Stormwater Management Handbook Vol. 2, Chapter 3)
 - 2. A portion of the site constitutes redevelopment
 - 3. Proprietary BMPs are included in the Stormwater Management System.
 b. No. Check why the project is exempt:
 - 1. Single-family house
 - 2. Emergency road repair
 - 3. Small Residential Subdivision (less than or equal to 4 single-family houses or less than or equal to 4 units in multi-family housing project) with no discharge to Critical Areas.

D. Additional Information

- This is a proposal for an Ecological Restoration Limited Project. Skip Section D and complete Appendix A: Ecological Restoration Notice of Intent – Minimum Required Documents (310 CMR 10.12).

Applicants must include the following with this Notice of Intent (NOI). See instructions for details.

Online Users: Attach the document transaction number (provided on your receipt page) for any of the following information you submit to the Department.

- 1. USGS or other map of the area (along with a narrative description, if necessary) containing sufficient information for the Conservation Commission and the Department to locate the site. (Electronic filers may omit this item.)
- 2. Plans identifying the location of proposed activities (including activities proposed to serve as a Bordering Vegetated Wetland [BVW] replication area or other mitigating measure) relative to the boundaries of each affected resource area.



Massachusetts Department of Environmental Protection
Bureau of Resource Protection - Wetlands

WPA Form 3 – Notice of Intent

Massachusetts Wetlands Protection Act M.G.L. c. 131, §40

Provided by MassDEP:	
MassDEP File Number	
Document Transaction Number	
Hull	
City/Town	

D. Additional Information (cont'd)

- 3. Identify the method for BVW and other resource area boundary delineations (MassDEP BVW Field Data Form(s), Determination of Applicability, Order of Resource Area Delineation, etc.), and attach documentation of the methodology.
- 4. List the titles and dates for all plans and other materials submitted with this NOI.
 - Nantasket Avenue Seawall Replacement
 - a. Plan Title
 - Jamison Fitzgerald Russell Titmuss
 - b. Prepared By c. Signed and Stamped by
 - 12/09/21 1" = 60'
 - d. Final Revision Date e. Scale
 - G-101, V-101, V-102, V-103, V-301, CA-101, CD-301, CS-111, CS-112 12/09/21
 - CS-112, CS-113, CS-311, CS-312 g. Date
- 5. If there is more than one property owner, please attach a list of these property owners not listed on this form.
- 6. Attach proof of mailing for Natural Heritage and Endangered Species Program, if needed.
- 7. Attach proof of mailing for Massachusetts Division of Marine Fisheries, if needed.
- 8. Attach NOI Wetland Fee Transmittal Form
- 9. Attach Stormwater Report, if needed.

E. Fees

- 1. Fee Exempt: No filing fee shall be assessed for projects of any city, town, county, or district of the Commonwealth, federally recognized Indian tribe housing authority, municipal housing authority, or the Massachusetts Bay Transportation Authority.

Applicants must submit the following information (in addition to pages 1 and 2 of the NOI Wetland Fee Transmittal Form) to confirm fee payment:

2. Municipal Check Number	3. Check date
4. State Check Number	5. Check date
6. Payor name on check: First Name	7. Payor name on check: Last Name



Massachusetts Department of Environmental Protection
Bureau of Resource Protection - Wetlands

WPA Form 3 – Notice of Intent

Massachusetts Wetlands Protection Act M.G.L. c. 131, §40

Provided by MassDEP:
MassDEP File Number
Document Transaction Number
Hull
City/Town

F. Signatures and Submittal Requirements

I hereby certify under the penalties of perjury that the foregoing Notice of Intent and accompanying plans, documents, and supporting data are true and complete to the best of my knowledge. I understand that the Conservation Commission will place notification of this Notice in a local newspaper at the expense of the applicant in accordance with the wetlands regulations, 310 CMR 10.05(5)(a).

I further certify under penalties of perjury that all abutters were notified of this application, pursuant to the requirements of M.G.L. c. 131, § 40. Notice must be made by Certificate of Mailing or in writing by hand delivery or certified mail (return receipt requested) to all abutters within 100 feet of the property line of the project location.

1. Signature of Applicant

4-26-22
2. Date

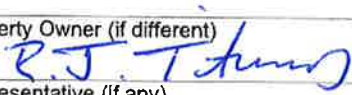
3. Signature of Property Owner (if different)

4. Date
4/26/2022

5. Signature of Representative (if any)

6. Date

For Conservation Commission:

Two copies of the completed Notice of Intent (Form 3), including supporting plans and documents, two copies of the NOI Wetland Fee Transmittal Form, and the city/town fee payment, to the Conservation Commission by certified mail or hand delivery.

For MassDEP:

One copy of the completed Notice of Intent (Form 3), including supporting plans and documents, one copy of the NOI Wetland Fee Transmittal Form, and a **copy** of the state fee payment to the MassDEP Regional Office (see Instructions) by certified mail or hand delivery.

Other:

If the applicant has checked the "yes" box in any part of Section C, Item 3, above, refer to that section and the Instructions for additional submittal requirements.

The original and copies must be sent simultaneously. Failure by the applicant to send copies in a timely manner may result in dismissal of the Notice of Intent.

Property Owners

948 Nantasket Ave

*Hulligans, LLC
5252 NW 85th Ave
#307
Doral, FL 33166*

1 Point Allerton Ave

*Barbara R Webster
1 Pt Allerton Ave
Hull, MA 02045*

955 Nantasket Ave

*John S and Sharyn M Hitchiner
36 Cider Mill Heights
North Granaby, CT 06060*



Massachusetts Department of Environmental Protection
 Bureau of Resource Protection - Wetlands
NOI Wetland Fee Transmittal Form
 Massachusetts Wetlands Protection Act M.G.L. c. 131, §40

Important: When filling out forms on the computer, use only the tab key to move your cursor - do not use the return key.



A. Applicant Information

1. Location of Project:

<u>Nantasket Ave</u>	<u>Hull</u>
a. Street Address	b. City/Town
<u>NA</u>	<u>NA</u>
c. Check number	d. Fee amount

2. Applicant Mailing Address:

<u>Philip</u>	<u>Lemnios</u>	
a. First Name	b. Last Name	
<u>Town of Hull</u>		
c. Organization		
<u>253 Atlantic Ave</u>		
d. Mailing Address		
<u>Hull</u>	<u>MA</u>	<u>02045</u>
e. City/Town	f. State	g. Zip Code
<u>781-925-2000</u>	<u>plemnios@town.hull.ma.us</u>	
h. Phone Number	i. Fax Number	j. Email Address

3. Property Owner (if different):

<u>See attached</u>		
a. First Name	b. Last Name	
c. Organization		
d. Mailing Address		
<u></u>	<u></u>	<u></u>
e. City/Town	f. State	g. Zip Code
<u></u>	<u></u>	<u></u>
h. Phone Number	i. Fax Number	j. Email Address

B. Fees

Fee should be calculated using the following process & worksheet. **Please see Instructions before filling out worksheet.**

Step 1/Type of Activity: Describe each type of activity that will occur in wetland resource area and buffer zone.

Step 2/Number of Activities: Identify the number of each type of activity.

Step 3/Individual Activity Fee: Identify each activity fee from the six project categories listed in the instructions.

Step 4/Subtotal Activity Fee: Multiply the number of activities (identified in Step 2) times the fee per category (identified in Step 3) to reach a subtotal fee amount. Note: If any of these activities are in a Riverfront Area in addition to another Resource Area or the Buffer Zone, the fee per activity should be multiplied by 1.5 and then added to the subtotal amount.

Step 5/Total Project Fee: Determine the total project fee by adding the subtotal amounts from Step 4.

Step 6/Fee Payments: To calculate the state share of the fee, divide the total fee in half and subtract \$12.50. To calculate the city/town share of the fee, divide the total fee in half and add \$12.50.

To calculate filing fees, refer to the category fee list and examples in the instructions for filling out WPA Form 3 (Notice of Intent).



Massachusetts Department of Environmental Protection
 Bureau of Resource Protection - Wetlands
NOI Wetland Fee Transmittal Form
 Massachusetts Wetlands Protection Act M.G.L. c. 131, §40

B. Fees (continued)

Step 1/Type of Activity	Step 2/Number of Activities	Step 3/Individual Activity Fee	Step 4/Subtotal Activity Fee

Step 5/Total Project Fee: _____

Step 6/Fee Payments:

Total Project Fee:	<u>NA</u>
	a. Total Fee from Step 5
State share of filing Fee:	<u>NA</u>
	b. 1/2 Total Fee less \$12.50
City/Town share of filing Fee:	<u>NA</u>
	c. 1/2 Total Fee plus \$12.50

C. Submittal Requirements

- a.) Complete pages 1 and 2 and send with a check or money order for the state share of the fee, payable to the Commonwealth of Massachusetts.

Department of Environmental Protection
 Box 4062
 Boston, MA 02211

- b.) **To the Conservation Commission:** Send the Notice of Intent or Abbreviated Notice of Intent; a **copy** of this form; and the city/town fee payment.

To MassDEP Regional Office (see Instructions): Send a copy of the Notice of Intent or Abbreviated Notice of Intent; a **copy** of this form; and a **copy** of the state fee payment. (E-filers of Notices of Intent may submit these electronically.)

HULL BOARD OF ASSESSORS

ABUTTERS LIST APPLICATION

DATE REQUESTED

- DATE PAID

MINIMUM OF ONE (1) WORKING DAY REQUIRED TO PRODUCE LIST

SUBJECT PROPERTY ADDRESS

MAP LOT _____ OWNER

REASON FOR ABUTTERS LIST

CONSERVATION COMMISSION
 TRAILERS HEARINGS

ALL PARCELS WITHIN 100' OF LOT LINES

ZONING BOARD OF APPEALS & SITE PLAN REVIEW
**ALL PARCELS WITHIN 300' OF LOT LINES
TWO SETS OF LABELS – ONE RECORD CARD**

COMMON VICTUALER LICENSE
 LIQUOR LICENSE
 ENTERTAINMENT LICENSE
ABUTTERS 300' (STREETS ARE TRANSPARENT)

OTHER _____

PROVIDE CRITERION FOR LIST

PERSON REQUESTING LIST

ADDRESS

TELEPHONE

LIST TO BE PICKED UP MAILED

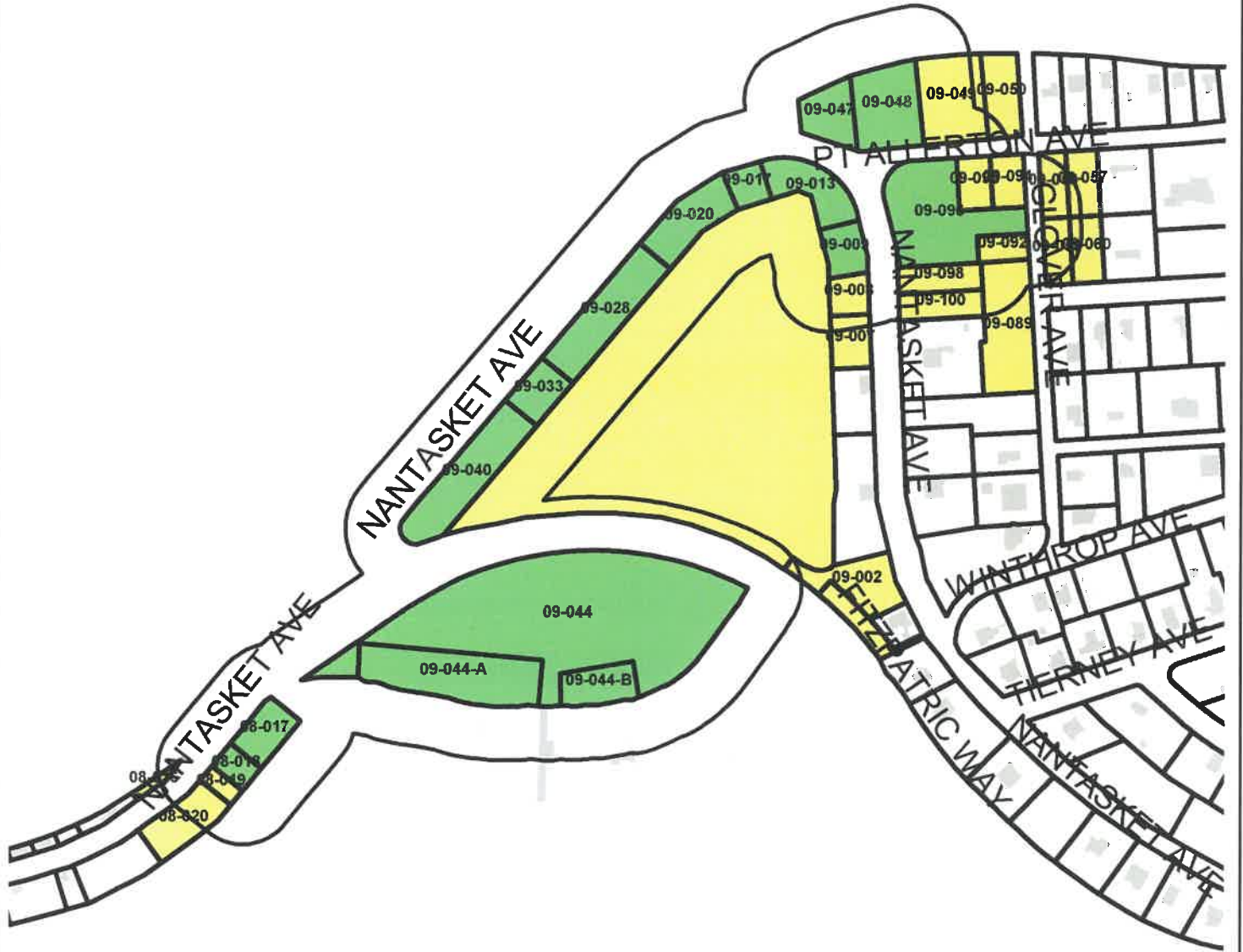

For assessment purposes only: not to be used in legal boundary descriptions.



Town of Hull
Assessors Office
253 Atlantic Avenue
Hull, MA 02045
781-925-2205

Abutters List Locus Map

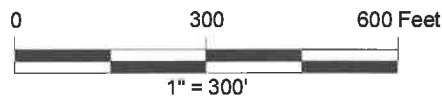

April 25, 2022

Multiple Subject Parcels Selected
Radius: 100'



**Town of Hull
Assessors Office**

LIST OF ABUTTERS TO.....

Parcel No.:
Owner:
Address:

939 NANTASKET AVE

April 25, 2022
2:57:26PM

Abutter's Name	Parcel Location	Parcel No. Book - Page	Mailing Address
WHITE JOHN S	1046 NANTASKET AVE	08-016 20012-3	WHITE JOHN S 1046 NANTASKET AVE HULL, MA 02045-0000
SABLE LINDA G	1039 NANTASKET AVE	08-019 609-15	SABLE LINDA G 35 STOCKBRIDGE ST COHASSET, MA 02025
THOMAS PHILLIP C & CONSTANCE N	1045 NANTASKET AVE	08-020 15422-143	THOMAS PHILLIP C & CONSTANCE N 1033 NANTASKET AVE HULL, MA 02045-0000
MAHONEY JOHN J JR & BETTE ANN	915 NANTASKET AVE	09-002 7849-179	MAHONEY JOHN J JR & BETTE ANN 915 NANTASKET AVE HULL, MA 02045-0000
CRUSE THOMAS J & ANNE F	933 NANTASKET AVE	09-007 27954-348	CRUSE THOMAS J & ANNE F 933 NANTASKET AVE HULL, MA 02045
WEBBER STEWART B & ANITA R	937 NANTASKET AVE	09-008 29360-349	WEBBER STEWART B & ANITA R 937 NANTASKET AVE HULL, MA 02045
PARISEAULT CHRIS & ELEANOR	9 PT ALLERTON AVE	09-049 53335-311	PARISEAULT CHRIS & ELEANOR 16 MARION ST HINGHAM, MA 02043
VINTON RAYMOND B & PAULA L	11 PT ALLERTON AVE	09-050 3675-16	VINTON RAYMOND B & PAULA L PO BOX 833 HULL, MA 02045-0000



**Town of Hull
Assessors Office**

LIST OF ABUTTERS TO....

Parcel No.:
Owner:
Address:

939 NANTASKET AVE

April 25, 2022
2:57:26PM

Abutter's Name	Parcel Location	Parcel No.	Book - Page	Mailing Address
PRIVETT BENJAMIN D & KATRINA L	16 PT ALLERTON AVE	09-057	9981-145	PRIVETT BENJAMIN D & KATRINA L 16 PT ALLERTON AVE HULL, MA 02045-0000
LEADER JACK & HABER JUDITH C	14 PT ALLERTON AVE	09-058	51653-215	LEADER JACK & HABER JUDITH C 613 CALIFORNIA ST NEWTON, MA 02460
FERGUSON COLLEEN	1 HOLBROOK AVE	09-059	43256-86	FERGUSON COLLEEN 1 HOLBROOK AVE HULL, MA 02045
CONNELLY JAMES & ANN J	3 HOLBROOK AVE	09-060	3494-1	CONNELLY JAMES & ANN J 3 HOLBROOK AVENUE HULL, MA 02045-0000
WILLIAMS RANDY E & HEIDI A	17 GLOVER AVE	09-089	54892-291	WILLIAMS RANDY E & HEIDI A 17 GLOVER AVENUE HULL, MA 02045
KAILIN JOHN L & DRENTLAW DIANE	23 GLOVER AVE	09-092	14749-179	KAILIN JOHN L & DRENTLAW DIANE 738 RUGBY RD BRYN MAWR, PA 19010
PHIPPEN WALTER & MARTHA J	12 PT ALLERTON AVE	09-094	7722-239	PHIPPEN WALTER & MARTHA J 12 PT ALLERTON AVE HULL, MA 02045-0000
JOHNSON BRUCE K	8 PT ALLERTON AVE	09-095	53565-253	JOHNSON BRUCE K 8 PT ALLERTON AVE HULL, MA 02045-0000



**Town of Hull
Assessors Office**

LIST OF ABUTTERS TO....

Parcel No.:

Owner:

Address:

939 NANTASKET AVE

Parcel No.

Book - Page

Parcel Location

Mailing Address

Abutter's Name

ANDERSON TIMOTHY C & COONEY P

936 NANTASKET AVE

09-098

5192-113

ANDERSON TIMOTHY C & COONEY PA
936 NANTASKET AVE

HULL, MA 02045-0000

VANDERGRIFT NATHAN L

934 NANTASKET AVE

09-100

55050-205

VANDERGRIFT NATHAN L
934 NANTASKET AVE

HULL, MA 02045

WHITE JOHN S
1046 NANTASKET AVE
HULL, MA 02045-0000

FERGUSON COLLEEN
1 HOLBROOK AVE
HULL, MA 02045

SABLE LINDA G
35 STOCKBRIDGE ST
COHASSET, MA 02025

CONNELLY JAMES & ANN J
3 HOLBROOK AVENUE
HULL, MA 02045-0000

THOMAS PHILLIP C & CONSTANCE N
1033 NANTASKET AVE
HULL, MA 02045-0000

WILLIAMS RANDY E & HEIDI A
17 GLOVER AVENUE
HULL, MA 02045

MAHONEY JOHN J JR & BETTE ANN
915 NANTASKET AVE
HULL, MA 02045-0000

KAILIN JOHN L & DRENTLAW DIANE
738 RUGBY RD
BRYN MAWR, PA 19010

CRUSE THOMAS J & ANNE F
933 NANTASKET AVE
HULL, MA 02045

PHIPPEN WALTER & MARTHA J
12 PT ALLERTON AVE
HULL, MA 02045-0000

WEBBER STEWART B & ANITA R
937 NANTASKET AVE
HULL, MA 02045

JOHNSON BRUCE K
8 PT ALLERTON AVE
HULL, MA 02045-0000

PARISEAULT CHRIS & ELEANOR
16 MARION ST
HINGHAM, MA 02043

ANDERSON TIMOTHY C & COONEY PA
936 NANTASKET AVE
HULL, MA 02045-0000

VINTON RAYMOND B & PAULA L
PO BOX 833
HULL, MA 02045-0000

VANDERGRIFT NATHAN L
934 NANTASKET AVE
HULL, MA 02045

PRIVETT BENJAMIN D & KATRINA L
16 PT ALLERTON AVE
HULL, MA 02045-0000

LEADER JACK & HABER JUDITH C
613 CALIFORNIA ST
NEWTON, MA 02460

WHITE JOHN S
1046 NANTASKET AVE
HULL, MA 02045-0000

FERGUSON COLLEEN
1 HOLBROOK AVE
HULL, MA 02045

SABLE LINDA G
35 STOCKBRIDGE ST
COHASSET, MA 02025

CONNELLY JAMES & ANN J
3 HOLBROOK AVENUE
HULL, MA 02045-0000

THOMAS PHILLIP C & CONSTANCE N
1033 NANTASKET AVE
HULL, MA 02045-0000

WILLIAMS RANDY E & HEIDI A
17 GLOVER AVENUE
HULL, MA 02045

MAHONEY JOHN J JR & BETTE ANN
915 NANTASKET AVE
HULL, MA 02045-0000

KAILIN JOHN L & DRENTLAW DIANE
738 RUGBY RD
BRYN MAWR, PA 19010

CRUSE THOMAS J & ANNE F
933 NANTASKET AVE
HULL, MA 02045

PHIPPEN WALTER & MARTHA J
12 PT ALLERTON AVE
HULL, MA 02045-0000

WEBBER STEWART B & ANITA R
937 NANTASKET AVE
HULL, MA 02045

JOHNSON BRUCE K
8 PT ALLERTON AVE
HULL, MA 02045-0000

PARISEAULT CHRIS & ELEANOR
16 MARION ST
HINGHAM, MA 02043

ANDERSON TIMOTHY C & COONEY PA
936 NANTASKET AVE
HULL, MA 02045-0000

VINTON RAYMOND B & PAULA L
PO BOX 833
HULL, MA 02045-0000

VANDERGRIFT NATHAN L
934 NANTASKET AVE
HULL, MA 02045

PRIVETT BENJAMIN D & KATRINA L
16 PT ALLERTON AVE
HULL, MA 02045-0000

LEADER JACK & HABER JUDITH C
613 CALIFORNIA ST
NEWTON, MA 02460

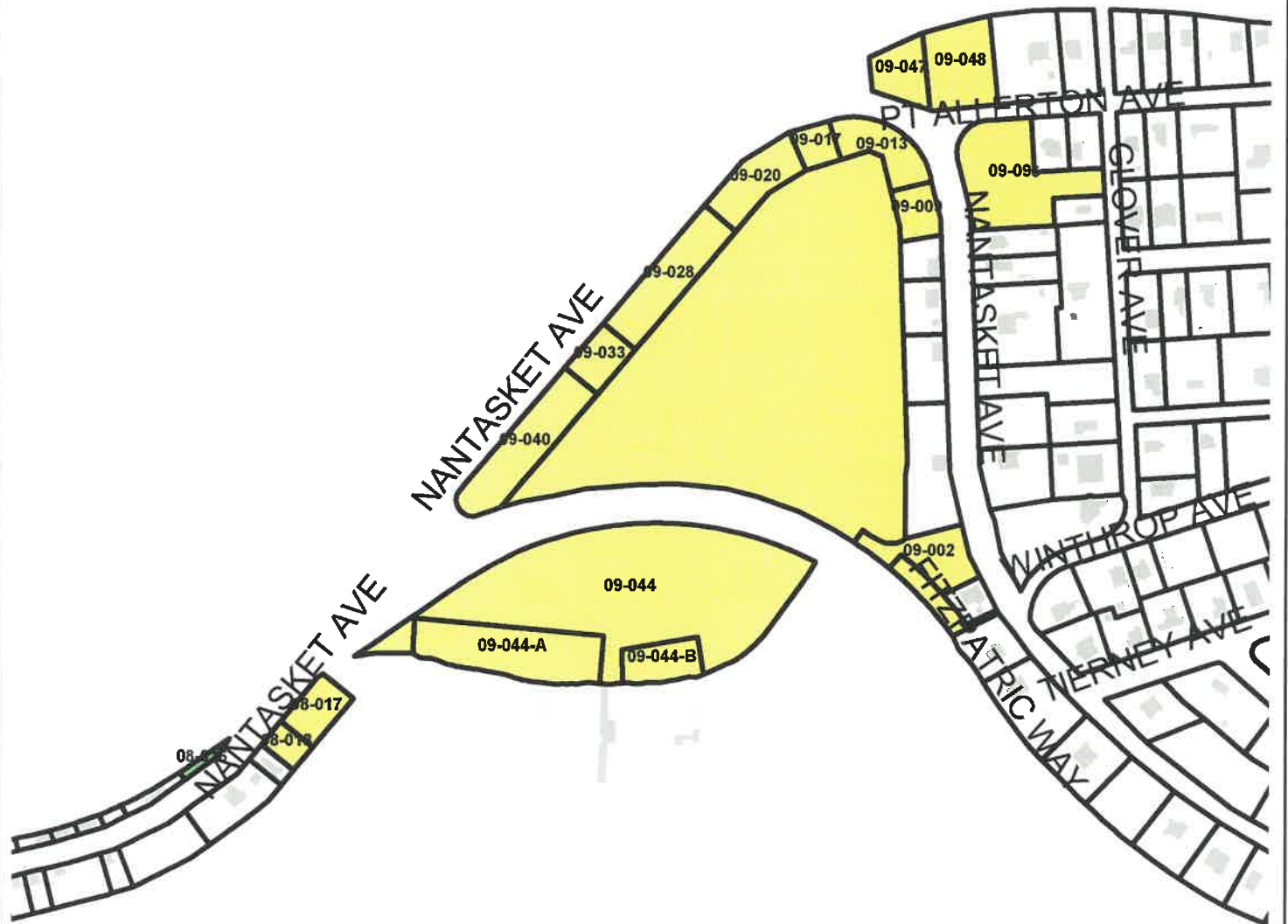

For assessment purposes only: not to be used in legal boundary descriptions.



Town of Hull
Assessors Office
253 Atlantic Avenue
Hull, MA 02045
781-925-2205

Abutters List Locus Map

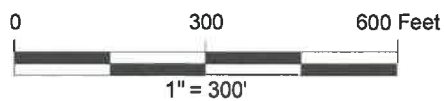

April 25, 2022

Subject Parcel ID: 08-016
Address: 1046 NANTASKET AVE



**Town of Hull
Assessors Office**

LIST OF ABUTTERS TO....

Parcel No.: 08-016
 Owner: WHITE JOHN S
 Address: 1046 NANTASKET AVE

April 25, 2022
 3:01:11PM

Abutter's Name	Parcel Location	Parcel No.	Book - Page	Mailing Address
THOMAS PHILLIP C & CONSTANCE M	1033 NANTASKET AVE	08-017	4575-59	THOMAS PHILLIP C & CONSTANCE M 1033 NANTASKET AVE HULL, MA 02045-0000
SMYTH WILLIAM N TRS	1037 NANTASKET AVE	08-018	49068-81	SMYTH WILLIAM N TRS 1037 NANTASKET AVE HULL, MA 02045-0000
MAHONEY JOHN J JR & BETTE ANN	915 NANTASKET AVE	09-002	7849-179	MAHONEY JOHN J JR & BETTE ANN 915 NANTASKET AVE HULL, MA 02045-0000
MARKUS CHRISTOPHER M	939 NANTASKET AVE	09-009	55093-189	MARKUS CHRISTOPHER M 939 NANTASKET AVE HULL, MA 02045
WEBSTER BARBARA R	0 NANTASKET AVE	09-013	11187-181	WEBSTER BARBARA R 1 PT ALLERTON AVE HULL, MA 02045-0000
HITCHINER JOHN S & SHARYN M	955 NANTASKET AVE	09-017	35998-2	HITCHINER JOHN S & SHARYN M 36 CIDER MILL HEIGHTS NORTH GRANBY, CT 06060
HUGHES TERRANCE L	0 NANTASKET AVE	09-020	118112-158	HUGHES TERRANCE L PO BOX 190 HULL, MA 02045-0000
HULL TOWN OF	0 NANTASKET AVE	09-028		HULL TOWN OF



**Town of Hull
Assessors Office**

April 25, 2022
3:01:11PM

LIST OF ABUTTERS TO....

Parcel No.: 08-016
Owner: WHITE JOHN S
Address: 1046 NANTASKET AVE

Abutter's Name	Parcel Location	Parcel No. Book - Page	Mailing Address
HUGHES TERRANCE L	0 NANTASKET AVE	09-033 118112-158	HUGHES TERRANCE L PO BOX 190 HULL, MA 02045-0000
HULL TOWN OF	0 NANTASKET AVE	09-040	HULL TOWN OF 0 NANTASKET AVE HULL, MA 02045-0000
TOWN OF HULL	0 FITZPATRICK WAY	09-044	TOWN OF HULL 253 ATLANTIC AVE HULL, MA 02045-0000
NANTASKET BEACH SALT WATER CL	3 FITZPATRICK WAY	09-044-A	NANTASKET BEACH SALT WATER CLU PO BOX 621 HULL, MA 02045-0000
HULL YACHT CLUB INC	5 FITZPATRICK WAY	09-044-B	HULL YACHT CLUB INC PO BOX 796 HULL, MA 02045-0000
HULLIGANS LLC	948 NANTASKET AVE	09-047 55498-253	HULLIGANS LLC 5252 NW 85TH AVE #307 DORAL, FL 33166
WEBSTER BARBARA R	1 PT ALLERTON AVE	09-048 11187-181	WEBSTER BARBARA R 1 PT ALLERTON AVE HULL, MA 02045-0000
GIDMAN JOHN R & BETH K	940 NANTASKET AVE	09-096 39545-160	GIDMAN JOHN R & BETH K 940 NANTASKET AVE HULL, MA 02045

THOMAS PHILLIP C & CONSTANCE M
1033 NANTASKET AVE
HULL, MA 02045-0000

TOWN OF HULL
253 ATLANTIC AVE
HULL, MA 02045-0000

SMYTH WILLIAM N TRS
1037 NANTASKET AVE
HULL, MA 02045-0000

NANTASKET BEACH SALT WATER CLU
PO BOX 621
HULL, MA 02045-0000

MAHONEY JOHN J JR & BETTE ANN
915 NANTASKET AVE
HULL, MA 02045-0000

HULL YACHT CLUB INC
PO BOX 796
HULL, MA 02045-0000

MARKUS CHRISTOPHER M
939 NANTASKET AVE
HULL, MA 02045

HULLIGANS LLC
5252 NW 85TH AVE #307
DORAL, FL 33166

WEBSTER BARBARA R
1 PT ALLERTON AVE
HULL, MA 02045-0000

WEBSTER BARBARA R
1 PT ALLERTON AVE
HULL, MA 02045-0000

HITCHINER JOHN S & SHARYN M
36 CIDER MILL HEIGHTS
NORTH GRANBY, CT 06060

GIDMAN JOHN R & BETH K
940 NANTASKET AVE
HULL, MA 02045

HUGHES TERRANCE L
PO BOX 190
HULL, MA 02045-0000

HULL TOWN OF

HUGHES TERRANCE L
PO BOX 190
HULL, MA 02045-0000

HULL TOWN OF
0 NANTASKET AVE
HULL, MA 02045-0000

THOMAS PHILLIP C & CONSTANCE M
1033 NANTASKET AVE
HULL, MA 02045-0000

TOWN OF HULL
253 ATLANTIC AVE
HULL, MA 02045-0000

SMYTH WILLIAM N TRS
1037 NANTASKET AVE
HULL, MA 02045-0000

NANTASKET BEACH SALT WATER CLU
PO BOX 621
HULL, MA 02045-0000

MAHONEY JOHN J JR & BETTE ANN
915 NANTASKET AVE
HULL, MA 02045-0000

HULL YACHT CLUB INC
PO BOX 796
HULL, MA 02045-0000

MARKUS CHRISTOPHER M
939 NANTASKET AVE
HULL, MA 02045

HULLIGANS LLC
5252 NW 85TH AVE #307
DORAL, FL 33166

WEBSTER BARBARA R
1 PT ALLERTON AVE
HULL, MA 02045-0000

WEBSTER BARBARA R
1 PT ALLERTON AVE
HULL, MA 02045-0000

HITCHINER JOHN S & SHARYN M
36 CIDER MILL HEIGHTS
NORTH GRANBY, CT 06060

GIDMAN JOHN R & BETH K
940 NANTASKET AVE
HULL, MA 02045

HUGHES TERRANCE L
PO BOX 190
HULL, MA 02045-0000

HULL TOWN OF

HUGHES TERRANCE L
PO BOX 190
HULL, MA 02045-0000

HULL TOWN OF
0 NANTASKET AVE
HULL, MA 02045-0000

1. Introduction

The Town of Hull proposes to rehabilitate the shoreline protection structures along Nantasket Avenue within the limits shown on Figure 1-1 below. These structures protect portions of Fitzpatrick Way and Nantasket Avenue. Fitzpatrick Way provides a critical link for access to and from Pemberton Point with the US Coastguard Station, two schools and over 700 private lots. Fitzpatrick Way is the critical roadway for emergency vehicle access but all utilities serving Pemberton Point are located in Nantasket Avenue. The structures included in this project include the Nantasket Avenue Seawall comprised of a higher wall and a lower wall running from the Point Allerton Seawall at the northern end to the Stony Beach Revetment at the southern end. The higher seawall was identified in the 2013 Coastal Hazard Infrastructure report as a High Priority structure in poor condition. This wall not only protects access to Pemberton with the utilities, but the sewer line for the entire town connects to the wastewater plant past this point. Loss of the road would cause failure of the sewer line to this treatment facility and spillage into the water would result.

The northern shoreline protected by Nantasket Avenue Seawall has some limited protection from Boston Harbor Islands including Brewster Island, Calf Island, Lovells Island and Georges Island. It is not exposed to the full force of the open Atlantic Ocean because of its orientation and location but it is exposed to the long fetches across the entrance to Boston Harbor of up to ten miles and sits in a very dynamic environment.

GEI Consultants Inc. performed a comprehensive study of the shoreline structures in this area with the goal of developing recommendations for repairs and upgrades to the coastal protection structures. The study was intended to allow a phased approach to rehabilitation based on need and funding availability.

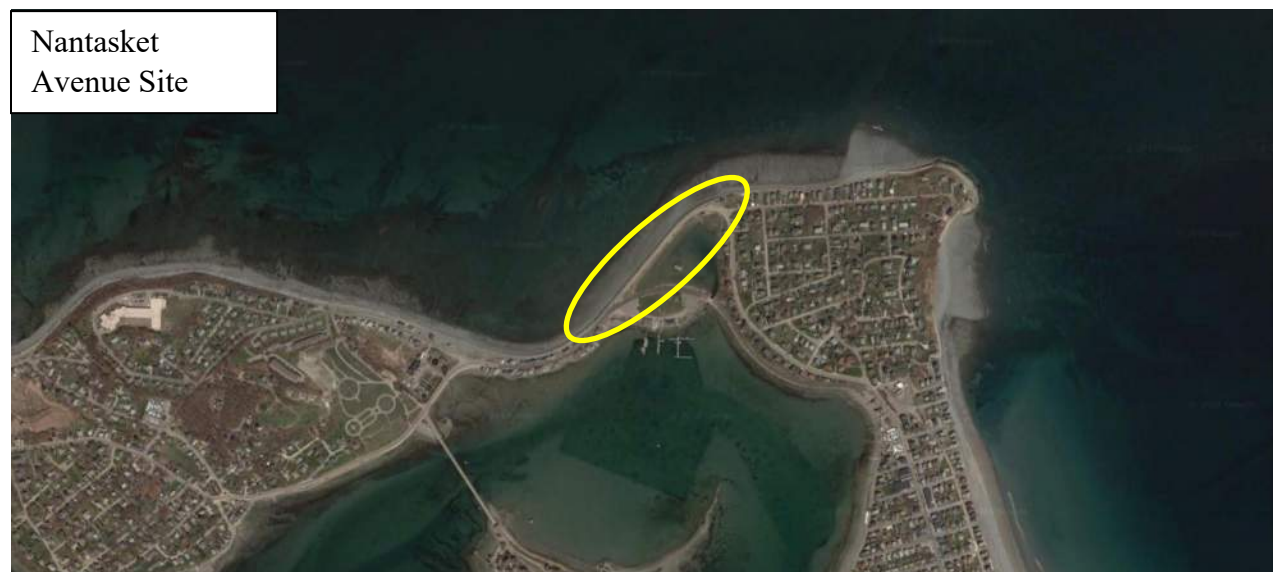

Figure 1-1 Locus Plan

2. Site Description

The site is located on the northern end of the Hull peninsula and includes approximately 1670 feet of coastline that runs along the northern shore of Nantasket Ave. It is not directly exposed to the open Atlantic Ocean but it is exposed to the long fetches across the entrance to Boston Harbor of up to ten miles. The entire shoreline is heavily armored and includes a large seawall with no toe protection and a smaller seawall with a revetment providing shoreline protection. The toe of the large seawall is at approximate elevation +8.0 feet MLW (Mean Low Water) and the top of the wall is at approximately +20.5 feet MLW. The toe of the revetment in front of the second seawall is at approximately +10.0 feet MLW while the top of wall is at approximately +18.0 MLW.

The northern shoreline is located within a FEMA VE zone with a base flood elevation of +21.0 feet NAVD (North American Vertical Datum), equivalent to +26.2 MLW. The beach outshore of the wall and revetment is comprised of coarse gravel, cobbles and small boulders ranging in diameter between 6 inches and 3 feet. Stone between 1 inch and 3 inch size was found near the seawall and was assumed to wash in and out with the tides as well as during storm events.

The typical beach condition outshore of the seawalls was consistent throughout the entire length of the Northern Shoreline. Surface material on the beach was comprised almost entirely of cobblestones and small boulders ranging in diameter between 6 inches and 3 feet although much larger boulders are also present. Gravel between 1 inch and 3 inches with sand was found near the concrete wall footing and sometimes throughout the rest of the beach.

The beach slope was approximately 1 vertical on 50 horizontal and Mean High Water was at or just above the toe of the structures.

In addition to protecting Fitzpatrick Way and Nantasket Avenue, it should also be noted that these seawalls also provide the primary protection to 4 homes and the more sheltered environment of Allerton Lagoon. Salt marsh is present around the shoreline of Allerton Lagoon and would likely be lost if these walls are not maintained.

3. Review of Existing Information

Historical documents relating to the site were obtained from the Town of Hull, local residents, the Massachusetts Coastal Infrastructure Inventory and Assessment Report Update and from online sources. These documents and drawings were reviewed and used to create a limited chronological history for the site.

Nantasket Avenue Seawall

Pre-1957 Concrete seawall roughly half the size of the existing seawall. Unknown build date.

1957 DPW Contract #1657 shows new seawall with cross section as existing.

1960 DPW Contract #2104 shows new seawall with cross section as existing. Cross section shown also includes a stone mound outshore of the new seawall approximately 16 feet wide and up to elevation +14 feet MLW.

2003 Fitzpatrick Way Bridge reconstructed and raised

2016 Stony Beach Revetment reconstructed and raised.

4. Existing Conditions

On December 26th and 27th, 2018 GEI performed a condition survey of the Fitzpatrick Way and Nantasket Ave shorelines. The condition survey consisted of a visual inspection with photo documentation of existing conditions. The inspection was performed at low tide to enable an inspection of all structural elements and surrounding beach conditions. Inspection was performed on an overcast day with temperatures around 35° F.

The condition assessments were based on a predefined five level rating system as used for the Massachusetts Coastal Infrastructure Inventory and Assessment Report. The system used ranged from Rating A for Excellent Condition to Rating F for Critical Condition as follows:

A	Excellent	Like new condition. Structure expected to withstand major coastal storm without damage.	None
		Stable landform (beach, dune or bank). Adequate system exists to provide protection from major coastal storm	
B	Good	Structure observed to exhibit very minor problems, superficial in nature. Minor erosion to landform is present.	Minor
		Structure / landform adequate to provide protection from a major coastal storm with no damage. Actions taken to prevent / limit future deterioration and extend life of structure	

C	Fair	<p>Structure is sound but may exhibit minor deterioration, section loss, cracking, spalling, undermining, and/or scour. Structure adequate to withstand major coastal storm with little to moderate damage. Actions taken to reinforce structure to provide full protection from major coastal storm and for extending life of structure.</p> <p>Moderate wind or wave damage to landform exists. Landform may not be sufficient to fully protect shoreline during a major coastal storm. Actions taken to provide additional material for full protection and extended life</p>	Moderate
D	Poor	<p>Structure exhibits advanced levels of deterioration, section loss, cracking, spalling, undermining, and/or scour. Structure has strong risk of significant damage and possible failure during a major coastal storm Structure should be monitored until repairs/reconstruction can be initiated. Actions taken to reconstruct structure to regain full capacity to resist a major coastal storm.</p> <p>Landform eroded, stability threatened. Landform not adequate to provide protection during major coastal storm. Actions taken to recreate landform to adequate limits for full protection from a major coastal storm.</p>	Major
F	Critical	<p>Conditions of structure/landform may warrant emergency stabilization as failure may result in potential loss of property and/or life. Landform eroded, loss of integrity</p> <p>Structure exhibits critical levels of deterioration, section loss, cracking, spalling, undermining, and/or scour. Structure provides little or no protection from a major coastal storm. Actions taken to totally reconstruct structure to regain full capacity.</p> <p>Landform stability is severely compromised, rate of erosion/material loss may be increasing, and landform does not provide adequate protection from a major coastal storm. Actions taken to recreate landform to adequate limits for full protection from a major coastal storm.</p>	Immediate

The five level priority rating system used for the Massachusetts Coastal Infrastructure Inventory and Assessment Report was also considered in determination of severity of the condition. This allowed for consideration of public infrastructure protection and density of residential housing to evaluate the overall importance of the structure for coastal protection. This rating included: evacuation routes; key public infrastructure including police, fire and hospital buildings; critical utility corridors and other areas of high public investment requiring greater protection. The ratings range from Level 1 for no infrastructure or residence protection to Level 5 for critical inshore infrastructure protection and/or high density residential.

I	None	No Inshore Structures or Residential Dwelling Units Present	Long Term Planning Considerations
II	Low Priority	Inshore Structures Present with Limited potential for Significant Infrastructure Damage	Future Project Consideration
III	Moderate Priority	Inshore Structures with potential for Infrastructure Damage and/or Limited Residential Dwellings (<1 dwelling impacted / 100 feet of shoreline)	Consider for Active Project Improvement Listing
IV	High Priority	High Value Inshore Structures with Potential for Infrastructure Damage and/or Moderate Density Residential Dwellings (1-10 dwellings impacted / 100 feet of shoreline)	Consider for Next Project Construction Listing
V	Immediate / Highest Priority	Critical Inshore Structures Present with Potential for Infrastructure Damage and/or High Density Residential Dwellings Conditions of structure may warrant emergency stabilization as failure may result in potential loss of property and/or life. (>10 dwellings impacted / 100 feet of shoreline)	Consider for Immediate Action Due to Public Safety and Welfare Issues

4.1 Typical Beach Conditions:

The typical beach condition outshore of the seawalls was consistent throughout the entire length of the Northern Shoreline. Surface material on the beach was comprised almost entirely of cobblestones and small boulders ranging in diameter between 3 inches and 3 feet although much larger boulders are also present. Gravel between 1 inch and 3 inches with sand was found near the concrete wall footing and sometimes throughout the rest of the beach. Below a depth ranging from over 3 feet near the wall to less than 1 foot 50 feet from the wall, there was a dense grey sandy gravelly silt.

The beach slope was approximately 1 vertical on 50 horizontal and Mean High Water was at or just above the toe of the structures.

4.2 Station 10+00 to Station 13+05 North: Low Nantasket Avenue Seawall with Revetment

Seawall

The top of the concrete seawall was at approximate elevation + 18.0 feet MLW and had a width of 2 feet at the top. Both the front and back face of the wall had no noticeable slope. The landward face of the seawall was aligned with the landward face of the adjacent High Nantasket Avenue Seawall described below. Typical for the low seawall were construction joints spaced approximately 10 feet on center along its entire length.

From STA 12+51 to 13+05 the concrete wall had severe cracking and spalling. The overall condition of the seawall over this length was considered failed (F) with the rest of the seawall considered as satisfactory (B).

Revetment

A placed stone revetment was present outshore of the concrete wall. The large armor stones varied in size between 6 feet long x 3 feet wide x 2 feet deep to 4 feet long x 3 feet wide x 1 foot deep. Some armor stones had been dislodged from the revetment and were spread out sporadically on the beach outshore of the revetment. Gravel and cobbles up to 8 inches in diameter were in between the armor stones and on the beach.

The revetment had a slope of approximately 2:1 and the beach at the toe of the revetment was at approximate elevation +10.0 feet MLW for its entire length. Before STA 12+75, the revetment crest elevation reached the top of the short seawall at elevation +18.0 feet MLW with a 4 foot wide crest between the top of the slope and the wall. After STA 12+75, the revetment crest elevation was +15.0 feet MLW, leaving the top 3 feet of the short seawall exposed. STA 13+10 marked the end of the placed stone revetment outshore of the seawall.

The overall condition of the revetment was considered fair (C).

4.3 Station 13+05 to Station 26+35 North: High Nantasket Avenue Seawall

Almost the entire length of Nantasket Avenue was protected by a large concrete seawall. The typical seawall condition along the entire length comprised an exposed concrete footing and recurved concrete wall stem. The beach elevation at the toe of the structure was at approximate elevation + 8 MLW for most of the length but some areas had deeper deposits of gravel and cobble raising the beach elevation locally. The top of the footing was at elevation + 10.5 MLW and the top of wall was at approximate elevation + 20.5 MLW. The front face of the stem sloped back with a ratio of 2.5:12 which led into a recurve. The top of the seawall was approximately 3 feet wide. The back of the wall had a 1:12 slope and was exposed above the street for two thirds of its height.

Seaward Face

The expansion joints along the entire seawall were typically ¼ inch wide but some were as big as 1 inch wide. These were spaced evenly at 50 foot intervals. Large vertical cracks were observed along the entire length of wall. The cracks ranged from ¼” to 2” wide and were equally spaced between

the expansion joints. This cracking is considered to be the result of concrete shrinkage in the unreinforced wall. Large horizontal cracks were observed along much of the seawall with the potential for failure of the unreinforced wall. Significant wall movement and rotation was evident. Past undermining of the exposed footing has caused differential movement at many of the joints and cracks. The movement was located at joints and large vertical cracks and the magnitude of movement varied between ½ inch and 2 inches.

Most parts of the wall had minor scaling along with hairline cracks on the front face and recurve region. In addition to this, the footings along the wall had rounded edges from abrasion.

The condition of this portion of wall was considered poor (D).

Landward Face

All vertical cracks that ran the full height of the wall on the seaward side also ran the full height on the landside of the seawall. Additionally, the differential movement noted above for the seaward face were also noted on the landward side. Horizontal hairline cracks that varied in width up to a ¼ inch were typical throughout the landward exposed face. Each section of seawall in between construction joints usually had one or more of these cracks. Some of these cracks had efflorescence leaking out of them.

All construction joints had some degree of soil washing out on the landward side of the wall. The size of the washout varied but was typically 1 foot long x 1 foot wide x 3 inches deep with up to a maximum of 2 feet long x 2 feet wide x 5 inches deep.

4.4 Station 26+35 to Station 26+75 North: Point Allerton Seawall

The Point Allerton portion of seawall had a previous cap repair to the original wall. Abrasion, spalling, some cracking and scaling were all found on the concrete wall. The overall condition of this section of wall was considered poor (D).

A 15 foot wide mound of large armor stone ranging in diameter between 2 feet and 7 feet sat outshore of this section of wall. The revetment had an approximate slope of 3:1 and varied in height between 3 feet and 5 feet closest to the wall. Some parts of the revetment stopped short of the wall, leaving a gap up to 4 feet wide. The overall condition of the revetment was considered poor (D).

5. Proposed Project Description

The proposed project consists of construction of new seawalls landward of the existing seawalls except at the connection to the Point Allerton Seawall at the northern end of the project. Due to the differing existing conditions along the site, the approach and the proposed cross section change according to location. A detailed alternative analysis was performed a part of the comprehensive study performed for the Town of Hull which is available upon request. The preferred options from that study were Option 4A New Seawall with Revetment and Option 4B New Seawall with Revetment behind existing wall. Those options have now been further refined and are described below.

5.1 STA 13+05 to STA 26+05

The existing High Wall runs from approximate STA 13+05 to STA 26+35. The proposed cross section for almost this entire length consists of a new seawall constructed approximately 11 feet landward of the existing back (landward face) of seawall.

For this length, Nantasket Avenue will be reduced in width to a single lane roadway. The proposed road cross section is shown on the Project Plans. The existing road in this length varies in elevation from approximately +14.0 MLW to +15.0 MLW. The 1% annual chance water elevation from the FEMA FIS at this site is +14.9 MLW. Adding sea level rise of 2.9 feet gives a projected still water elevation of +17.8 MLW. The proposed single lane road will be reconstructed and the design allows for it to be reconstructed to at least elevation +18.0 MLW. This may be achieved in stages due to the limited life of the road construction and the need to tie into Fitzpatrick Way which will not be raised in the short term. The existing water and gas utilities run along the southern side of the existing road and will remain in place. The overhead electric and cable lines which currently run on the northern side close to the seawall will be relocated to the southern side of the road.

The proposed concrete seawall will be constructed with a top elevation of +22.5 MLW. The wall will be shaped with a recurve to reduce overtopping discharge. In addition, the existing wall will only be partly demolished and the strip between the remnants of the old wall and the new wall will be armored with large 4 to 5 ton individual weight armor stones. The old wall and the armor will provide additional absorption of wave energy and will reduce the overtopping discharge to less than 0.02 ft³/sec/linear foot of wall for the 1% annual event storm condition including the 2.9 feet of sea level rise.

In order to protect against potential undermining of the remnants of the existing wall, geotextile and stone or short sheet piles will be provided to prevent fill loss below the old wall foundation. This approach avoids new construction seaward of the existing wall and there will be no new resource area impacts offshore of the high tide line for this length.

5.2 STA 26+05 to STA 26+75

This length represents the transition from the new seawall cross section described above back outshore to the existing seawall alignment. The transition is necessary to avoid the house at #948 Nantasket Avenue and to connect to the existing seawall at Point Allerton Avenue. The proposed alignment has been designed to achieve both of these goals and to provide a smooth transition between the different wall profiles.

A vertical cut will be made through the existing seawall and the section to the north will be completely demolished and removed for this length. The existing seawall cross section at Point Allerton Avenue includes a toe revetment and the proposed design extends this revetment by an additional 25 feet to smooth the transition and to protect the “cut end” of the remaining portion of the existing Nantasket Avenue Seawall.

The proposed new seawall cross section through this length will be similar the new seawall described in the section above but the design will allow for a crest elevation of up to +24.5 MLW to provide additional protection to the house.

The combination of the revetment extension and the proposed wall alignment results in a new impact of approximately 700 square feet offshore of the High Tide Line (HTL). Of this area, 380 square feet is below Mean High Water (MHW). Estimated volume of dredging (excavation for revetment toe) for this area is 350 cubic yards. Dredged materials will be reused on site with granular material being placed back on the beach and any underlying silt will be used as fill upland on the site.

5.3 STA 10+00 to STA 13+05

The existing Low Wall runs up to approximate STA 13+05 from the Stony Beach Revetment. The proposed cross section for this entire length will be a new concrete seawall with armor stone revetment. To the maximum extent practical and to avoid new impacts, the offshore toe of the new revetment has been placed to be at the same location as the existing revetment toe. This results in a new seawall alignment approximately 11 feet landward of the existing back of wall. A short section from approximate STA 10+80 to 11+50 has to be located slightly closer to the sea to avoid impacting the Fitzpatrick Way road width. Fitzpatrick Way is a two lane road in this area and has to remain so because it is the only road to Point Pemberton.

The proposed concrete seawall will be constructed with a top elevation of +24.5 MLW and the wall will be shaped with a recurve to reduce overtopping discharge. The armor stone revetment offshore of the wall will have a crest elevation of +19.5 MLW and an offshore slope of 1 vertical to 2 horizontal. The overtopping discharge will be less than 0.003 ft³/sec/linear foot of wall for the 1% annual event storm condition including the 2.9 feet of sea level rise.

There is a slight increase in resource area impacts. The revetment toe will be located up to 2 feet seaward of the existing for a portion of the length resulting in a new area of impact of 450 square feet. Estimated volume of dredging (excavation for revetment toe) for this area is 700 cubic yards. Similar to the section 5.2 above, dredged materials will be reused on site.

5.4 Beach Monitoring and Maintenance Plan

The project proposes to incorporate the remnants of the existing seawall into the overall cross section to provide improved coastal storm protection. The gap between the existing and the new seawalls will be filled with large armor stone to further dissipate wave energy.

The existing seawall has shown signs of undermining in the past and this beach monitoring and maintenance plan proposes a means to maintain the stability of the remnants of the old wall. The old wall foundation will be connected to the new wall to prevent it rotating seaward but beach nourishment will be used if the beach level erodes lower than existing elevations.

5.4.1 Beach Monitoring

The existing survey of the beach performed April 11, 2019, will provide the baseline elevations for monitoring the beach and comparison.

Periodic beach monitoring surveys will be performed on an annual basis in the month of September and after major storms if beach elevations are noted to be impacted. The periodic surveys will be compared to the baseline survey for the 30 foot wide zone on the ocean side and measured from the existing seawall.

- The average beach elevation will be computed over the entire length of the wall.
- If the average beach elevation is lowered by 6 inches or more over the entire length of the wall, a repeat survey may be performed within 8 weeks to determine if the average beach elevation remains lower.
- If the average beach elevation remains lowered by 6 inches or more over the entire length of the wall but no undermining is observed, a repeat survey may be performed within 6 months to determine if the average beach elevation remains lower.
- In order to evaluate more localized reduction in beach elevations, the wall will be divided into 100 foot lengths and the average change in beach elevation will be computed over each 100 foot length.

5.4.2 Beach Nourishment

Beach Nourishment will be performed to restore beach elevations in the vicinity of the seawall under the conditions set out below.

- If undermining of the existing seawall is observed, the volume of material lost over the length of the undermining and over a 30 foot wide zone in front of the wall will be computed. An equal volume of beach nourishment material will be placed over the length of the undermining and within a 10 foot wide zone on the ocean side of the existing wall.
- If the average beach elevation over any 100 foot length is lowered by 12 inches or more, the volume of material lost over the 100 foot length and over a 10 foot wide zone in front of the wall will be computed. A volume of beach nourishment material equal to twice the volume lost will be placed over the 100 foot length and within a 10 foot wide zone on the ocean side of the existing wall.
- If the average beach elevation is lowered by 6 inches or more over the entire length of the wall, the Town may elect to place beach nourishment material at the eastern end of the project. The volume placed may be up to the volume lost over the entire length of the wall. Material will be placed up to 3 feet thick and over sufficient length to allow all placement within a strip 10 feet wide on the ocean side of the existing seawall. Maximum volume to be placed on an annual basis is 900 cubic yards. Actual volume placed on an annual basis will depend on need.
- Beach nourishment material will be placed by equipment operating from the roadway on the landward side of the wall. Material will be lifted in an excavator bucket or similar and placed within the 10 foot wide strip outshore of the original seawall.

- All beach nourishment material will match the existing average beach grading as determined by onsite sampling and measurement by GEI on September 29, 2021.

SIZE	% PASSING BY WEIGHT
18"	100
12"	70 – 90
6"	60 – 75
3"	30 – 60
1.5"	18 – 45
1"	14 – 40
3/4"	10 – 35
1/2"	0 - 15

5.5 Summary of Project Impacts

The project site is entirely within Land Subject to Coastal Storm Flowage and area mapped as Barrier Beach. However, the entire area of the site with the exception of 1150 square feet of expansion seaward is a previously altered developed environment. The majority of the project area comprises road pavement and the unpaved strips alongside the road pavement.

There will be temporary construction impacts to Land subject to Coastal Storm Flowage and to the mapped Barrier Beach Area. Total area impacted will be 2.2 acres as the new wall and revetments are constructed and the roadways are reconstructed. There is a slight net reduction in impervious area because some roadway width is being removed and replaced with a combination of the concrete wall and the armor stone between the old and new walls.

Expansion seaward of 1150 square feet impacts Coastal Beach/Rocky Intertidal resource area. This area will become revetment armor stone.

The summary table below shows pre and post construction areas. It should be noted that most of the new riprap armor area is armor stone placed between the old seawall and the new seawall. The current use of the space between the two wall alignments is as an unpaved gravel/soil strip alongside the road pavement.

Summary of Areas of Impact		
	Existing Area (Square feet)	Proposed Area (Square feet)
Land subject to Coastal Storm Flowage and Barrier Beach – Coastal Dune		
Roadways	45600	35725
Concrete seawalls	5750	10250
Riprap armor	6350	24150
Other (Grass strip, loose gravel, etc)	24650	13375
Barrier Beach - Coastal Beach		
Revetment Construction	1150	0
Beach Nourishment (when required)	12800	12800
TOTAL	96300	96300

5.6 Construction

The proposed wall will be constructed from the landward side of the existing walls except for the short section near the northeastern end when the new wall has to connect to the Point Allerton seawall. Demolition of the existing wall and construction of the new wall can all be accessed from the existing road. Concrete and other materials from the old wall will be crushed and reused onsite to the extent practical in order to minimize the need for offsite material disposal.

The revetment construction at the southwestern end and at the northeastern will be performed by construction equipment working mostly from the landward side. Excavation for the toe of the revetment will need to be performed by equipment operating on the beach. All sand, gravel and cobbles will be placed over the toe of the new revetment to remain on the beach. Any finer silt containing material will be removed from the beach and taken upland for reuse as fill in the project. Any such excavation will be performed in the dry at lower tide conditions and no use of a silt curtain is proposed.

Excavation equipment is not expected to need to track along the beach for any distance because the demolition of the existing walls at each end will allow access ramps to be constructed into the shoreline for the short duration that such access is necessary.

Armor stone will be placed by equipment operating from the landside of the existing wall.

5.7 Stormwater Management During Construction

The Site Contractor will be responsible for stormwater management of the active construction site and is required to adhere to the conditions of the 2012 Construction General Permit under the Environmental Protection Agency and any other permits issued by local, state, and federal agencies. A SWPPP will be prepared in accordance with the MassDEP Stormwater Management Standards and the 2012 Construction General Permit and will be submitted to the Hull Conservation Commission prior to construction.

6. MassDEP Stormwater Management Standards

The Project is redevelopment under the DEP Stormwater Management System. The Site will be designed to meet or exceed the MassDEP Stormwater Management Standards as summarized below:

Standard 1: No New Untreated Discharges

The proposed project will comply with this Standard. There will be no new untreated stormwater discharges, or discharges that cause erosion, into waters of the Commonwealth. The project includes reconstruction and reduction in width of an existing road. There will be no new untreated discharges. One existing outfall will be removed and will be replaced by use of infiltration.

Standard 2: Peak Rate Attenuation

The proposed impervious width of road will be reduced and the peak discharge will therefore be reduced. The site is located within Land subject to Coastal Storm Flowage and this standard can be waived.

Standard 3: Groundwater Recharge

This standard is not applicable to a redevelopment project but the proposed drainage system seeks to increase infiltration by use of the wide vegetated shoulder along the edge of the road.

Standard 4: Water Quality Treatment

No major changes are proposed to the existing runoff patterns on the site. There is one catchbasin at the low spot in the existing road vertical profile at approximate STA 18+30 which will be removed. The reconstructed road will be approximately 3 feet higher in elevation than the existing road and will slope to the south. The reconstructed road pavement will be reduced in width from approximately 26 feet to 15 feet. A 2% cross slope will direct sheet flow to the vegetated strip along the south side of the road. The vegetated strip is a minimum of 6 feet wide and will use engineered planting soil to function partly as bioretention and thereby improve existing conditions. This solution is proposed for four primary reasons:

1. A more conventional stormwater capture, treatment and discharge would require channeling the flow to low points along the road. The seawall is not designed to prevent all wave overtopping and much higher flow rates will occur periodically during the most severe storms. If the road is profiled to direct stormwater flows, the overwash from waves will also be channeled and will overwhelm catch basins and curbs. When the system is overloaded,

the excess flow will all run over the face of the embankment and will cause erosion of the embankment and shoreline areas of the lagoon. If sheet flow is maintained, a more uniform flow will occur over the vegetated strip which will not cause erosion.

2. The proposed road surface is narrow resulting in lower runoff per foot of road length than for the existing road and although narrower than desirable, the vegetated strip width equals 40% of the proposed road width.
3. Limited width is available because the road is between the proposed seawall and the top of the existing embankment slope. Widening of the embankment to make additional space is undesirable because of the associated impacts on wetland resource areas.
4. The road already contains multiple utilities and the narrow road width does not allow sufficient space for adding below ground stormwater capture and treatment system.

Source control and pollution prevention measures, such as street sweeping, proper snow management, and stabilization of eroded surfaces, are included in the Long-Term Pollution Prevention Plan and Operation and Maintenance Plan (Appendix H).

Standard 5: Land Uses with Higher Potential Pollutant Loads

This site is not a land use with higher potential pollutant load and the standard is not applicable.

Standard 6: Critical Areas

No direct discharge is proposed. The project seeks to improve existing conditions by increasing infiltration. The higher elevation road will increase the separation between the infiltration surface and the annual high water table. The project will not discharge untreated stormwater to a sensitive resource area. This project complies with this standard to the extent practicable due to the very limited space available.

Standard 7: Redevelopments

The project is considered a redevelopment project and the following Stormwater Management Standards will be met to the maximum extent practicable: the pretreatment and structural best management practice requirements of Standards 4, 5, and 6 (see compliance narrative for Standards 4, 5, and 6). Existing stormwater discharges will comply with Standard 1 because there will be no new discharges. Standard 2 is not applicable because the site is in Land subject to Coastal Storm Flowage although there will be a reduction in impervious area. Standard 3 is not practicable to meet fully but the proposed design seeks to improve existing conditions. This project will comply with all other requirements of the Stormwater Management Standards and improve existing conditions (see compliance narratives for Standards 8, 9, and 10).

Standard 8: Construction Period Pollution Prevention and Sedimentation Control

The project plans submitted with the Wetlands Notice of Intent require the installation of erosion and sediment control measures around the perimeter of the work zone. In practice only a sub section of the project site will be disturbed at any one time and sediment and erosion control measures will be relocated and maintained as the project construction advances.

Since the Project will disturb more than one (1) acre of land, a Notice of Intent will be submitted to the Environmental Protection Agency (EPA) for coverage under the National Pollution Discharge Elimination System (NPDES) Construction General Permit. As part of this application the Applicant is required to prepare a Stormwater Pollution Prevention Plan (SWPPP) and implement the measures in the SWPPP. The SWPPP, which is to be kept on site, includes erosion and sediment controls (stabilization practices and structural practices), temporary and permanent stormwater management measures, Contractor inspection schedules and reporting of all SWPPP features, materials management, waste disposal, off-site vehicle tracking, spill prevention and response, sanitation, and non-stormwater discharges. A copy of the SWPPP will be provided to the Conservation Commission prior to start of construction.

Standard 9: Operation and Maintenance Plan

A post-construction operation and maintenance plan has been prepared and will be implemented to ensure that stormwater management systems function as designed. Source control and stormwater BMP operation requirements for the site are summarized in the Long-Term Pollution Prevention Plan and Operation and Maintenance Plan provided in Appendix D.

Standard 10: Prohibition of Illicit Discharges

There will be no illicit discharges to the stormwater management system associated with the Project because no subsurface pipe network is proposed.

7. Natural Resources and Performance Standards

Natural resources data on or adjacent to the project site was obtained by both onsite inspection and from the MA GIS and MA CZM websites using “Massmapper” data viewers. (see Appendix C)

Natural resource areas are shown on the project plans and include the following:

- The entire length of Nantasket Ave is mapped as a barrier beach but Fitzpatrick Way and the Hull Yacht Club are not within the limits.
- No eelgrass is mapped in the vicinity of the shoreline.
- The beach to the north of the Nantasket Seawall is mapped as “Area Suitable for Shellfish” and is designated as suitable for Blue Mussel.
- The full length both the northern and southern shorelines border Natural Heritage Estimated and Priority Habitats (PH 1324), but the limit of the mapped Priority Habitat is offshore, and significantly outside any likely construction limits.

7.1 Land Containing Shellfish

310 CMR 10.24 (4) through (8) shall apply

The proposed project will impact 830 SF of Land Containing Shellfish and is mapped as suitable for blue mussel (*Mytilus edulis*). As per 310 CMR 10.24(4) the project will not alter water circulation or relief elevation. There will be no compaction of sediment or alteration of sediment grain size distribution. The drainage from adjacent land will remain and the completed project will not result in a change to water quality. The project will not permanently destroy shellfish habitat and shellfish are expected to repopulate the area naturally (310 CMR 10.24(5)). The Town does not anticipate the need to move or replant shellfish from the project area (310 CMR 10.24(6)). The project does not propose to increase productivity of shellfish habitat and is not an aquaculture project (310 CMR 10.24(7)). The project will not have any adverse effect of specified habitat or rare species (310 CMR 10.24(9)).

7.2 Rocky Intertidal Shore

310 CMR 10.31 states:

(3) When a Rocky Intertidal Shore Is Determined to Be Significant to Storm Damage Prevention, Flood Control, or Protection of Wildlife Habitat, any proposed project shall be designed and constructed, using the best practical measures, so as to minimize adverse effects on the form and volume of exposed intertidal bedrock and boulders.

(4) When a Rocky Intertidal Shore is Determined to Be Significant to the Protection of Marine Fisheries or Wildlife Habitat, any proposed project shall if water-dependent be designed and constructed, using best available measures, so as to minimize adverse effects, and if non-water-dependent, have no adverse effects, on water circulation and water quality. Water quality impacts include, but are not limited to, other than natural fluctuations in the levels of dissolved oxygen, temperature or turbidity, or the addition of pollutants.

The proposed project will result in impacts to 1,150 SF of Rocky Intertidal Shores. These impacts will be minimized to the greatest extent practicable and will minimize effects on form and volume of exposed intertidal bedrock and boulders (310 CMR 10.31 (3)). There are no anticipated adverse effects on water circulation or water quality (310 CMR 10.31(4)). The project will not have any adverse effect of specified habitat or rare species (310 CMR 10.31(5)).

7.3 Barrier Beach / Coastal Beach / Land Subject to Coastal Storm Flowage / Coastal Dune

The entire project site is within area mapped as Barrier Beach although the majority of the site has now lost its natural characteristics.

The table below is summary of the impacts to Barrier Beach / Coastal Beach and Coastal Dune withing the project site.

Summary of Areas Pre and Post Construction		
	Existing Area (Square feet)	Proposed Area (Square feet)
Land subject to Coastal Storm Flowage and Barrier Beach – Coastal Dune		
Roadways	45600	35725
Concrete seawalls	5750	10250
Riprap armor	6350	24150
Other (Grass strip, loose gravel, etc)	24650	13375
Barrier Beach - Coastal Beach		
Revetment Construction	1150	0
Beach Nourishment (when required)	12800	12800
TOTAL	96300	96300

Summary of Areas of Impact									
	Existing Area (Square feet)	Temporary Impacts	Roadway raised	Changes (square feet)					Proposed Area (Square feet)
				From Roadway	To/from Concrete seawall	To Riprap	To/from Other	To/from Coastal Beach	
Land subject to Coastal Storm Flowage and Barrier Beach – Coastal Dune									
Roadways	45600	18350	27250		-5350	0	-4525		35725
Concrete seawalls	5750	5750		850	4500	-850			10250
Riprap armor	5300	5300			850		16850	1150	24150
Other (Grass strip, loose gravel, etc.)	25700	19340	6360	4525		-16850			13375
Barrier Beach - Coastal Beach									
Revetment	1150							-1150	0
Coastal Beach	12800	12800						0	12800
TOTAL	83500								96300

In the above table, positive value under changes indicates increase in area, negative value indicates decrease in area e.g. For the line “Roadways”, -5350 in the column headed “To/from Concrete Seawall” indicates that Roadway area will be reduced by 5,350 square feet and will change to Concrete Seawall. Temporary impacts are areas that will be removed and reconstructed in kind or, in the case of the seawalls, the upper portion will be removed and the lower portion will remain.

Approximately 1,050 cy of Coastal Beach will be dredged to provide a stable toe of slope for the revetment in the sections labeled 10+00 – 13+15 and 26+00 – 26+75. The work is defined as dredging because it is outshore of the high water line but the “dredging” will be performed an excavator working during periods of low tide. Dredged materials will be reused on site with granular material being placed back on the beach and any finer material will be used as fill upland on the site.

Performance standards for Coastal Dune / Barrier Beach can be found in **3.10 CMR 10.28 (3) through (6)**

310 CMR 10.28 (3)

The proposed project will not have an adverse effect on the ability of waves to remove sand from the dune, will not disturb the existing vegetative cover or destabilize the dune. The seawall reconstruction will not cause any modification of the dune that would increase potential for storm or flood damage. The proposed project will not interfere with the movement of the dune, cause the removal of sand or interfere with mapped or identified bird nesting habitat.

310 CMR 10.28 (4)

This performance standard is not applicable to this project as no new accessory buildings are proposed. The project is for the replacement of existing structures.

310 CMR 10.28 (5)

The project, which is reconstruction of an existing roadway and seawall, has been designed to minimize disturbance to the existing area. There is no bird nesting habitat (310 CMR 10.28 (5(a))) identified in the project area. The project does not propose any fencing or other devices designed to increase dune development. The plantings proposed for stormwater control will be native vegetative cover.

310 CMR 10.28 (6)

The project is not anticipated to have any impact on rare species as none have been identified in the project area.

The entire project area has been identified as Land Subject to Coastal Storm Flowage. The entire project area (2.2 acres) is located within VE (EL 15), VE (EL 21), and the AE (EL 13) zones, as depicted in the FEMA Flood Insurance Rate Map #250269 (see Appendix D).

7.4 Temporary Construction Impacts

In addition to the above listed impacts there will be temporary construction impacts at both ends of

the project where access to the beach will be required for machines to excavate for the toe of the new/reconstructed revetments. Impacts to these areas will consist of excavation for the toe of the revetments. After the toe stones are set, the beach will be backfilled and the beach will be restored to the existing elevations. The entire impact is to resource area mapped as Barrier Beach-Coastal beach and the total area is 6500 square feet. All machine access to approach these areas will be from the landside of the existing wall. The yellow colored areas on the figures below illustrate the areas impacted. These areas are in addition to the tabulated areas above.

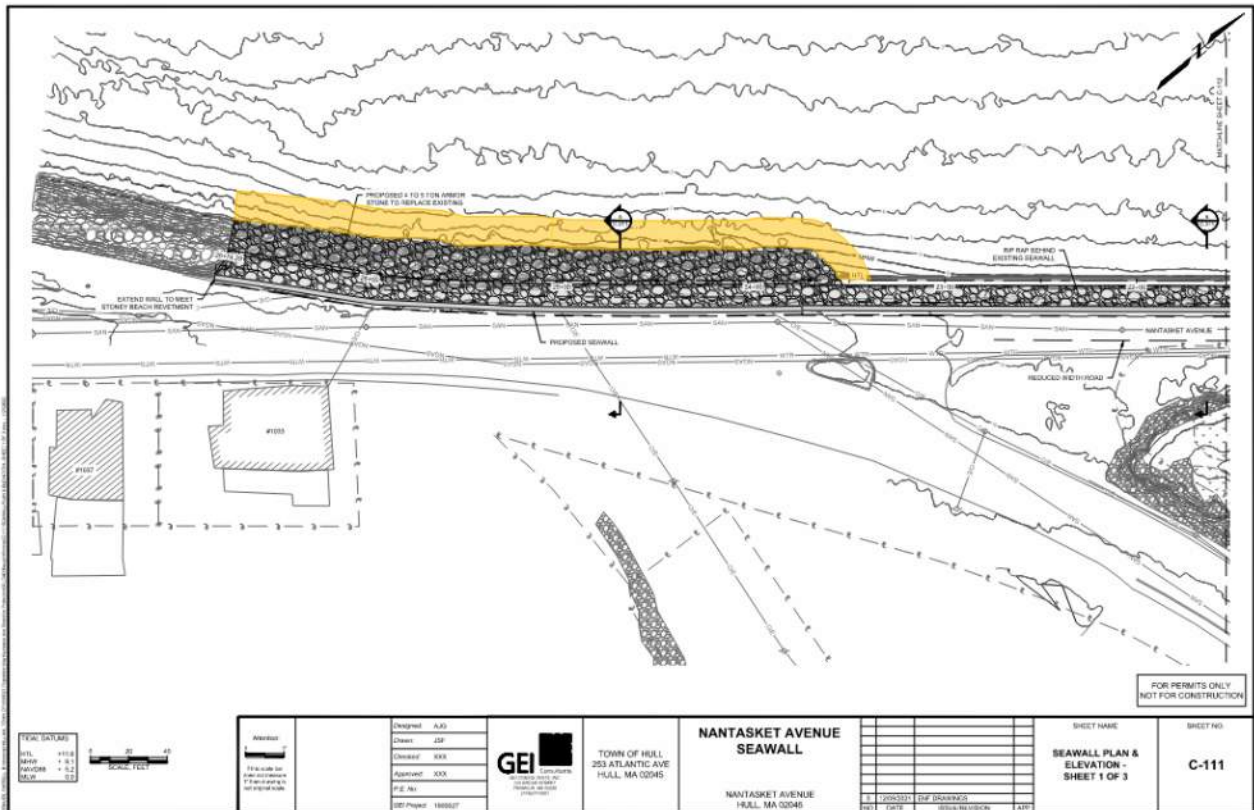

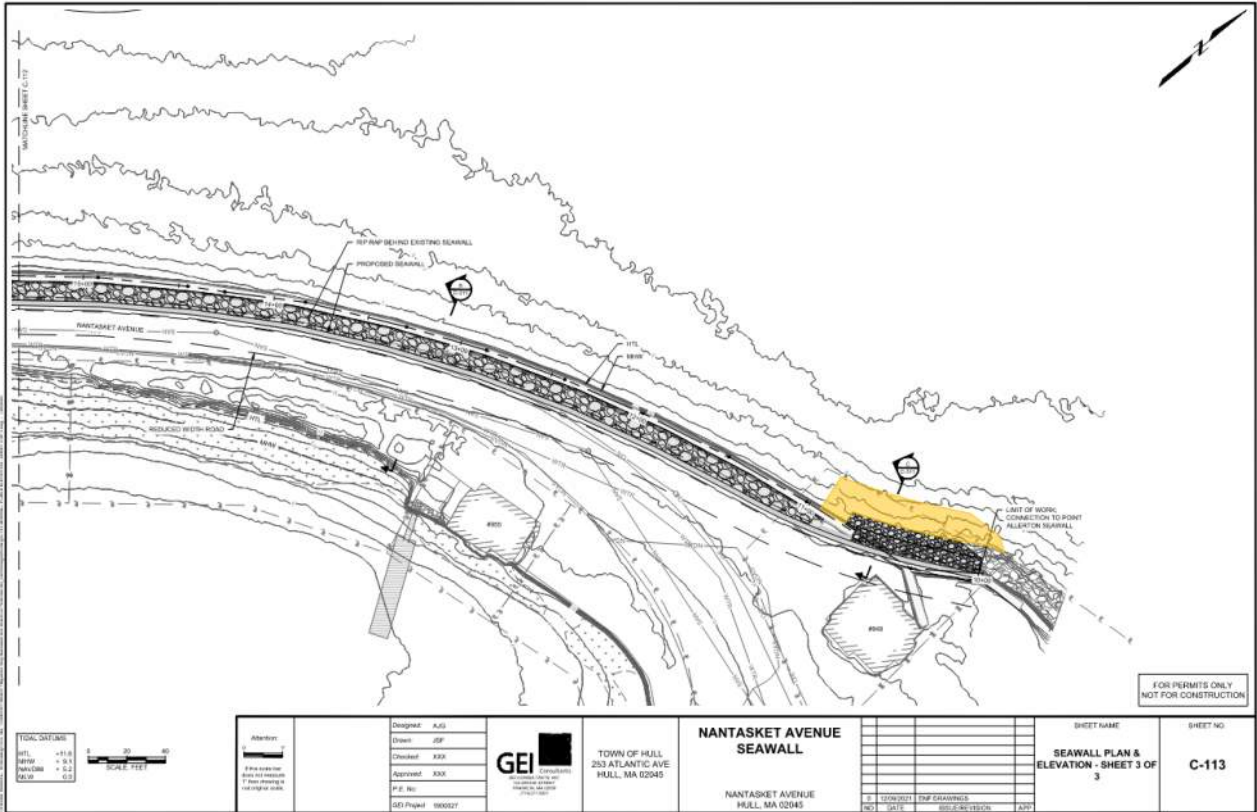

FOR PERMITS ONLY
NOT FOR CONSTRUCTION

TIDAL DATUMS	
M.T.L.	+11.8
M.H.W.	+9.1
M.L.W.	+6.2
L.L.W.	0.0

Attention:
 1. This plan was prepared by GEI
 2. Any changes to this plan must be approved by GEI

Designed	AJD
Drawn	JDF
Checked	XXX
Approved	XXX
P.E. No.	
GEI Project	1000007



TOWN OF HULL
 253 ATLANTIC AVE
 HULL, MA 02045

NANTASKET AVENUE SEAWALL
 NANTASKET AVENUE
 HULL, MA 02045

NO.	DATE	DESCRIPTION	APP.

SHEET NAME
SEAWALL PLAN & ELEVATION - SHEET 3 OF 3

SHEET NO
C-113

Appendix A

Project Plans

Appendix B

Site Photographs



Nantasket Seawall STA 10+00 to STA 11+00



Nantasket Seawall STA 11+00 to STA 12+50



Nantasket Seawall STA 12+50 to STA 14+00



Nantasket Seawall STA 14+00 to STA 15+50



Nantasket Seawall STA 15+50 to STA 17+30



Nantasket Seawall STA 17+30 to STA 19+30



Nantasket Seawall STA 19+30 to STA 21+30



Nantasket Seawall STA 21+30 to STA 23+30



Nantasket Seawall STA 23+30 to STA 24+75



Nantasket Seawall STA 24+75 to STA 26+25



Nantasket Seawall STA 26+25 to STA 26+74









Appendix C

MA GIS Data

Nantasket Ave Sewall - DEP Wetlands

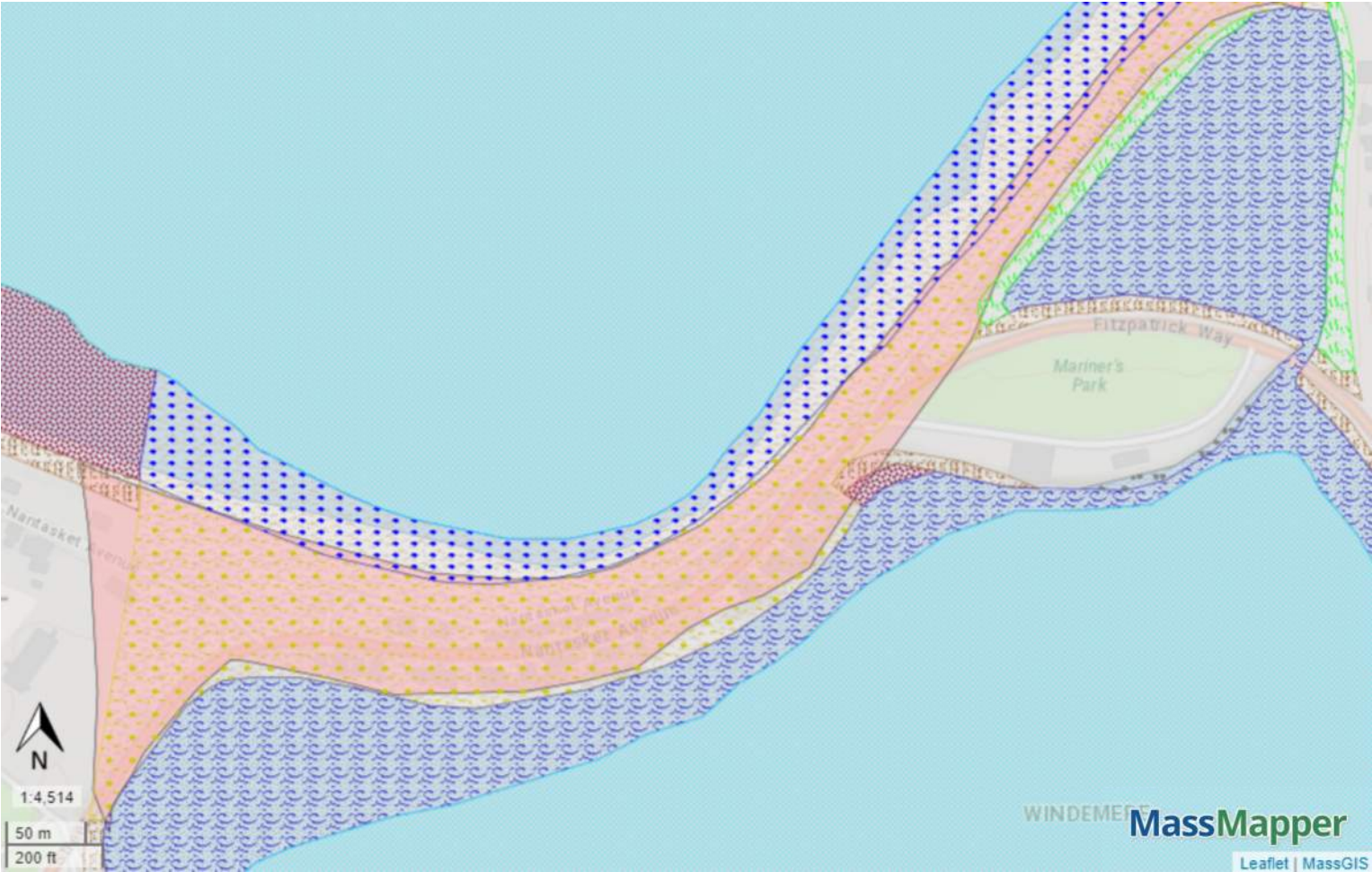

DEP Wetlands Detailed With Outlines

- Barrier Beach System
- Barrier Beach-Deep Marsh
- Barrier Beach-Wooded Swamp Mixed Trees
- Barrier Beach-Coastal Beach
- Barrier Beach-Coastal Dune
- Barrier Beach-Marsh
- Barrier Beach-Salt Marsh
- Barrier Beach-Shrub Swamp
- Barrier Beach-Wooded Swamp Coniferous
- Barrier Beach-Wooded Swamp Deciduous
- Bog
- Coastal Bank Bluff or Sea Cliff
- Coastal Beach
- Coastal Dune
- Cranberry Bog
- Deep Marsh
- Barrier Beach-Open Water
- Open Water
- Rocky Intertidal Shore
- Salt Marsh
- Shallow Marsh Meadow or Fen
- Shrub Swamp
- Tidal Flat
- Wooded Swamp Coniferous
- Wooded Swamp Deciduous
- Wooded Swamp Mixed Trees

Barrier Beaches



Nantasket Ave Seawall

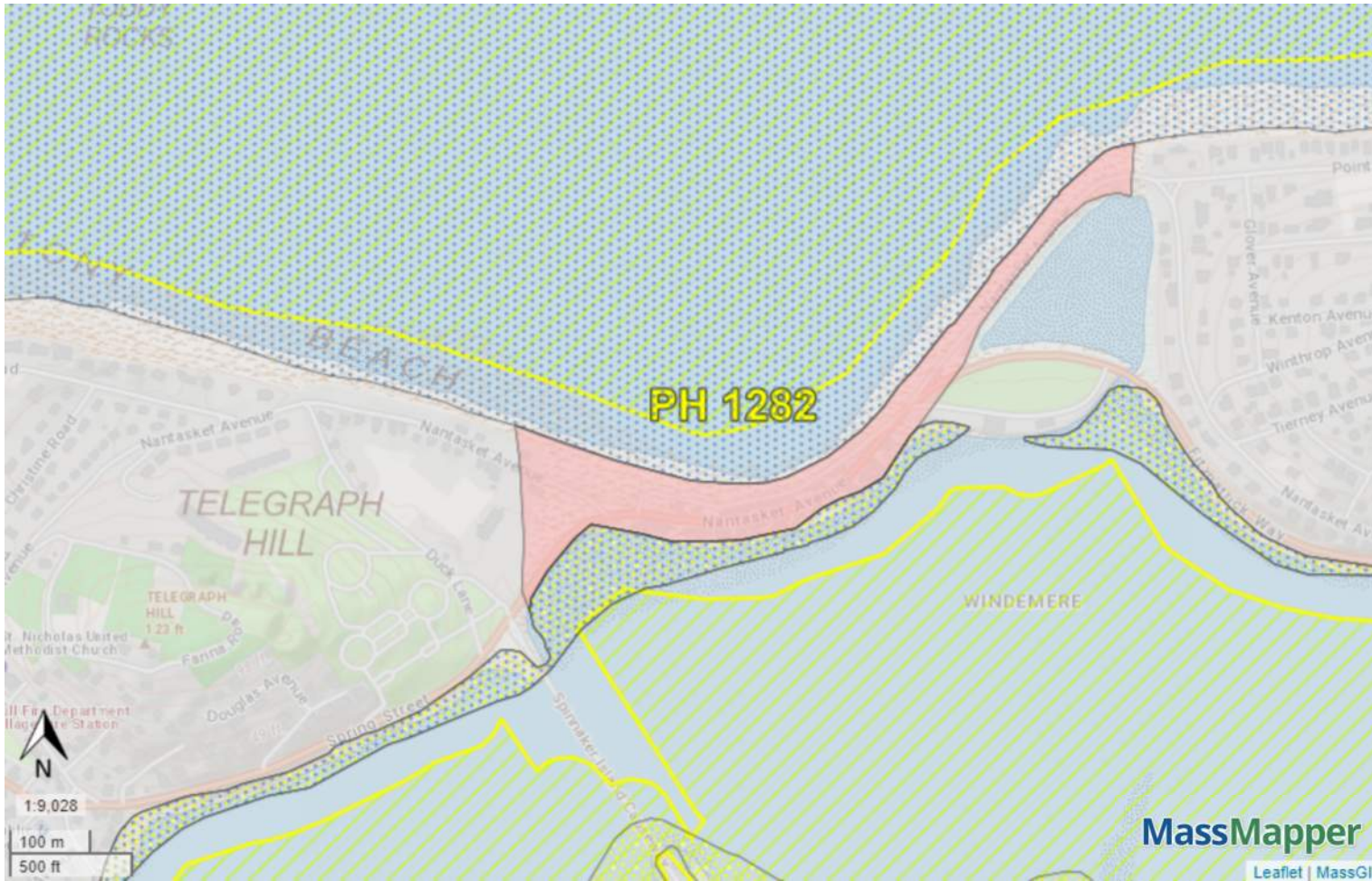

MassDEP Seagrass 2019-2022



Shellfish Suitability Areas

- AMERICAN OYSTER
- BAY SCALLOP
- BLUE MUSSEL
- EUROPEAN OYSTER
- OCEAN QUAHOG
- QUAHOG
- RAZOR CLAM
- SEA SCALLOP
- SOFT-SHELLED CLAM
- SURF CLAM

Barrier Beaches



NHESP Priority Habitats of Rare Species



NHESP Estimated Habitats of Rare Wildlife



Appendix D

FEMA Flood Insurance Rate Map Extracts

Broad Sound

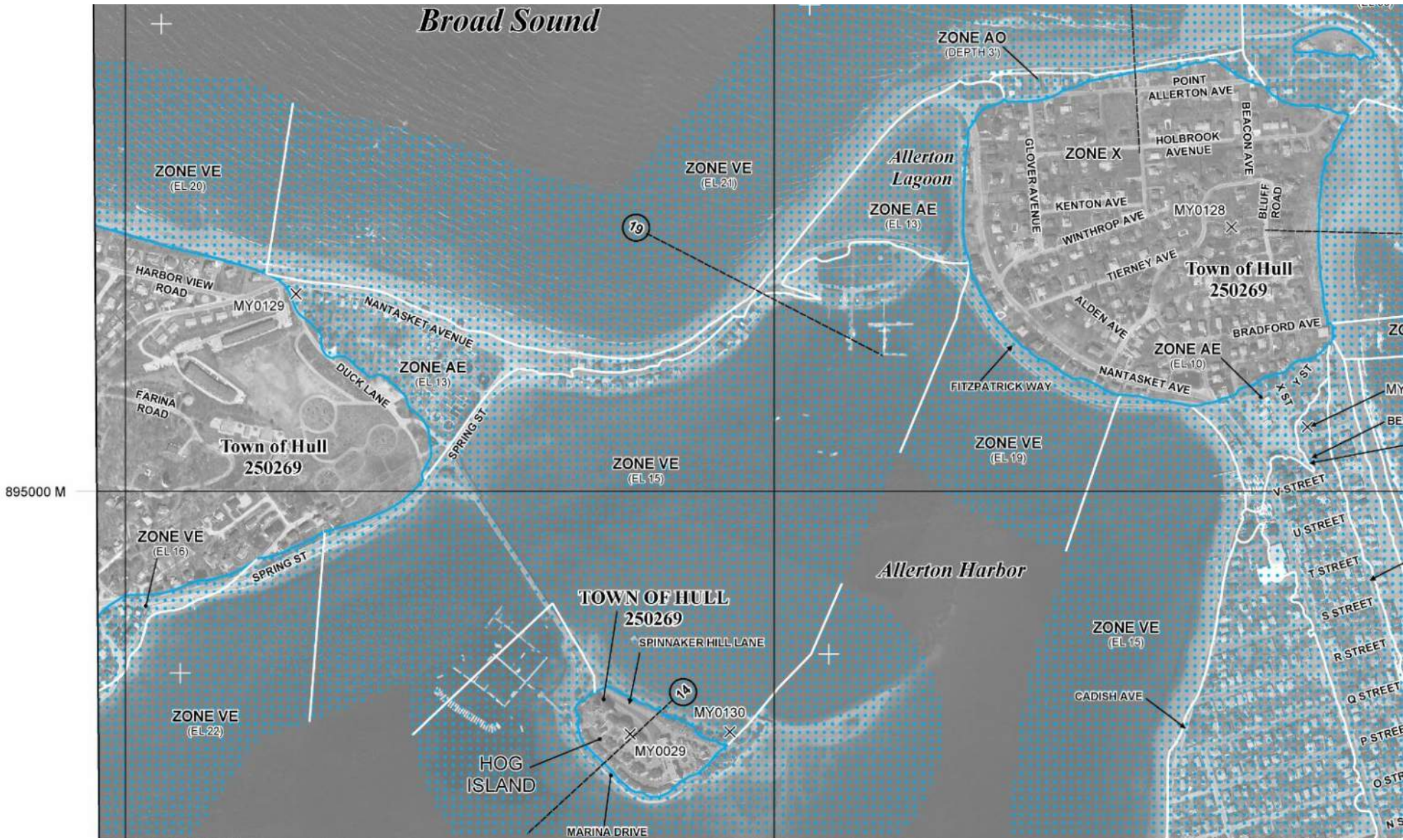

Appendix E

Wave Analysis and Overtopping

Wave Analysis

The Nantasket Avenue Seawall is located on the northern shoreline of Hull and is partially exposed to open ocean waves from the Northeast which approach in a direction almost parallel to the wall. These waves will refract and bend around towards a more direct attack but they will still approach obliquely. The shoreline is exposed to longer fetches for wind generated waves across Boston Harbor but, it is partially protected by multiple islands across the harbor entrance as shown in Figure E-1. The seawall is more directly exposed to the NW with local fetches as shown in Figure E-2.



Figure E-1 Nantasket Avenue Harbor Fetch



Figure E-2 Nantasket Seawall Shoreline Fetches

Wind data from Logan Airport and from NOAA data buoy 44013 offshore of Boston Harbor was used as the basis for estimating wind speeds for given return periods. Wind data from Logan Airport was based on 2-minute duration wind speeds and the NOAA data buoy provided 8-minute duration windspeeds. Data was sorted and used to estimate wind speeds for 10, 25, 50 and 100-year return periods. It is important to note that this data is historic and cannot take into account any future impacts of climate change on storm severity. In reviewing the data, there is relatively little difference in the Logan Airport data and the data buoy records and a relatively small range in the wind speeds for the relevant directions reported. A maximum value was taken to represent windspeeds for the local wave analysis for any of the relevant directions for the respective sites. Table E-1 shows the estimated wind speeds to be used for wave height estimation for this project.

Table E-1 Estimated Wind Speeds (2-minute duration)

Project	Sector	Return Period			
		10-year	25-year	50-year	100-year
		Mph	Mph	Mph	Mph
Nantasket Ave Seawall	WSW to NNE	44.8	50.6	54.9	59.2

Estimated open ocean wave conditions were based on the 20-year hindcast data taken from WIS Station 51. Table E-2 shows the data based on previous reports.

Table E-2 Open Ocean Wave Heights (Hmo) and Periods (Tp) propagating to Pt Allerton, Hull

Sector	Return Period (years)					
	25		50		100	
	Height (ft)	Period (sec)	Height (ft)	Period (sec)	Height (ft)	Period (sec)
NE	23.3	12.1	25.2	12.3	26.9	12.5
ENE	23.4	12.1	26.4	12.3	27	12.5
ESE	22.9	12	26.4	12.7	30	13.5

Shoreline wave heights were estimated using the wave transformation method by Goda and based on estimated water depths at the toe of each structure. Water depths for wave prediction purposes for the Nantasket Seawall were based on a toe of wall elevation of +8.0 feet MLW at the outshore limit of the existing structure which is representative for most of the length.

Still Water elevations were taken from the FEMA Flood Insurance Study (2016) for Plymouth

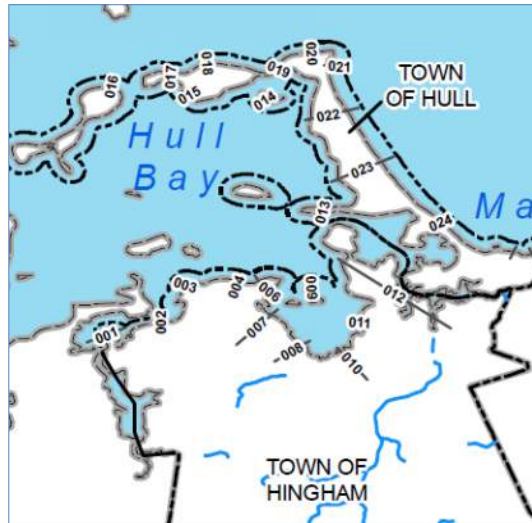

Figure E-3 Extract from Figure 2 of Flood insurance Study for Plymouth County, MA

County at Transect 20 as shown in Figure E-3 and Table E-3 below.

Table E-3 Stillwater Flood Elevations (from Plymouth County FIS)

Transect #	Return Period (years)					
	10-year Elevation		50-year Elevation		100-year Elevation	
	NAVD	MLW	NAVD	MLW	NAVD	MLW
19	8.4	13.6	9.3	14.5	9.7	14.9

The Still Water elevations were then increased to account for predicted Sea Level rise. Anticipated sea level rise figures for the site are based on the climate change projections published on the website resilientma.org. The sea level projections are provided by decade for three locations within Massachusetts (Boston, Falmouth, and Nantucket). Boston is the nearest location and therefore selected as most appropriate for water level projections in Hull. The website provides sea level projections for four different scenarios based on chance of exceedance which are as follows: intermediate (17%), intermediate-high (5%), high (0.5%), extreme (0.1%). This analysis is based on a minimum sea level rise corresponding to an intermediate-high scenario which has an unlikely to exceed probability of 95 percent. Sea level rise predictions were based on Year 2070 and the
 GEI Consultants, Inc.

Intermediate High scenario which result in an estimated sea level rise of 2.9 feet.

Wave conditions for use in calculating armor size, runup and overtopping discharge were estimated using the ocean wave exposure and the cross harbor fetch analysis. Ocean waves were transformed using the method by Goda giving estimated wave heights as shown in Table E-4 below. Wave heights at the structures were based on water depth using the 1% annual chance storm (100-year return event) plus 2.9 feet to represent sea level rise over the expected life of the new seawall structures.

Table E-4 Predicted Wave Heights (feet) - Ocean Waves at toe of Structures

	Return Period (Years)			
	25 Year	50 Year	100 Year	100 Year + 2.9ft
H_s (ft)	6.24	6.97	7.34	9.41
H_{max} (ft)	9.23	10.2	10.72	13.36
T_p (sec)	12.1	12.3	12.5	12.5

The local fetch analysis was performed using the windspeeds set out in Table E-1. Fetch data used for wave estimation is as shown in Figure E-1 and Figure E-2. Wave heights were estimated using the applet from the Automated Coastal Engineering System (ACES) software. Wave heights were estimated for 10-year, 50-year and 100-year return periods.

The estimated wave heights and associated wave periods for local fetch generated waves on the north shoreline at Nantasket Seawall are shown in Table E-5 and Table E-6.

Table E-5 Predicted Wave Heights (feet) Nantasket Avenue Harbor Waves

	Return Period (Years)			
	10 Year	50 year	100 Year	100 Year + 2.9ft
H_s (ft)	3.61	5.03	4.9	5.12
H_{max} (ft)	4.95	5.81	6.19	8.37
T_p (sec)	3.74	4.1	4.24	4.25

Table E-6 Predicted Wave Heights (feet) – Nantasket Seawall Local Fetch

	Return Period (Years)			
	10 Year	50 year	100 Year	100 Year + 2.9ft
H_s (ft)	2.13	2.74	3.01	3.04
H_{max} (ft)	3.83	4.92	5.4	5.48
T_p (sec)	2.9	3.25	3.39	3.41

Overtopping Analysis and Design

Overtopping Methods

Estimates of overtopping were made using methods presented in the USACE Manual EM 1110-2-1100 “Coastal Engineering Manual” (CEM) and using ACES software.

For proposed cross sections with both a revetment and a seawall, the method by Bradbury and Alsop was used as detailed in the USACE Manual EM 1110-2-1100 (Part VI) Table VI-5-9.

Limits on average overtopping discharge were based on critical values as presented in the CEM in Table VI-5-6 of the manual and as shown in Figure E-5. These critical values are based on limiting damage or providing safety to vehicles and pedestrians behind the structure.

Table E-4 provides a summary of the critical overtopping discharges taken from the CEM.

Table E-4 Critical Overtopping Discharges

Safety Criterion	Metric units	Imperial Units
Damage to unprotected back slopes	20 liters/sec/m	0.21 ft ³ /sec/ft
Damage to unprotected crest	2 liters/sec/m	0.021 ft ³ /sec/ft
Erosion of grassed areas (Start of Damage)	1 liters/sec/m	0.010 ft ³ /sec/ft
Vehicle Safety	0.33 liters/sec/m	0.0035 ft ³ /sec/ft
Pedestrian safety	0.23 liters/sec/m	0.0025 ft ³ /sec/ft
Building damage	0.03 liters/sec/m	0.0003 ft ³ /sec/ft

The primary goal for the coastal protection structures at this site is to avoid damage to the roadways and utilities in order to maintain the critical links to the infrastructure, homes and businesses to the west on Point Pemberton. Fitzpatrick Way is a critical link for access to and from Pemberton Point with the US Coastguard Station, two schools and over 700 private lots. Fitzpatrick Way is the critical roadway for emergency vehicle access and all of the utilities are in Nantasket Avenue. Critically, the sewer line for the entire town connects to the wastewater plant past this point. Loss of the road would cause failure of the sewer line to this treatment facility and spillage into the water would result. It is presumed that the roads would not be in use by the general public during the height of a severe storm. However, emergency vehicles may need to pass so vehicle safety should be taken into account.

Figure E-5 Extract from CEM "Critical Values of Average Overtopping Discharges"

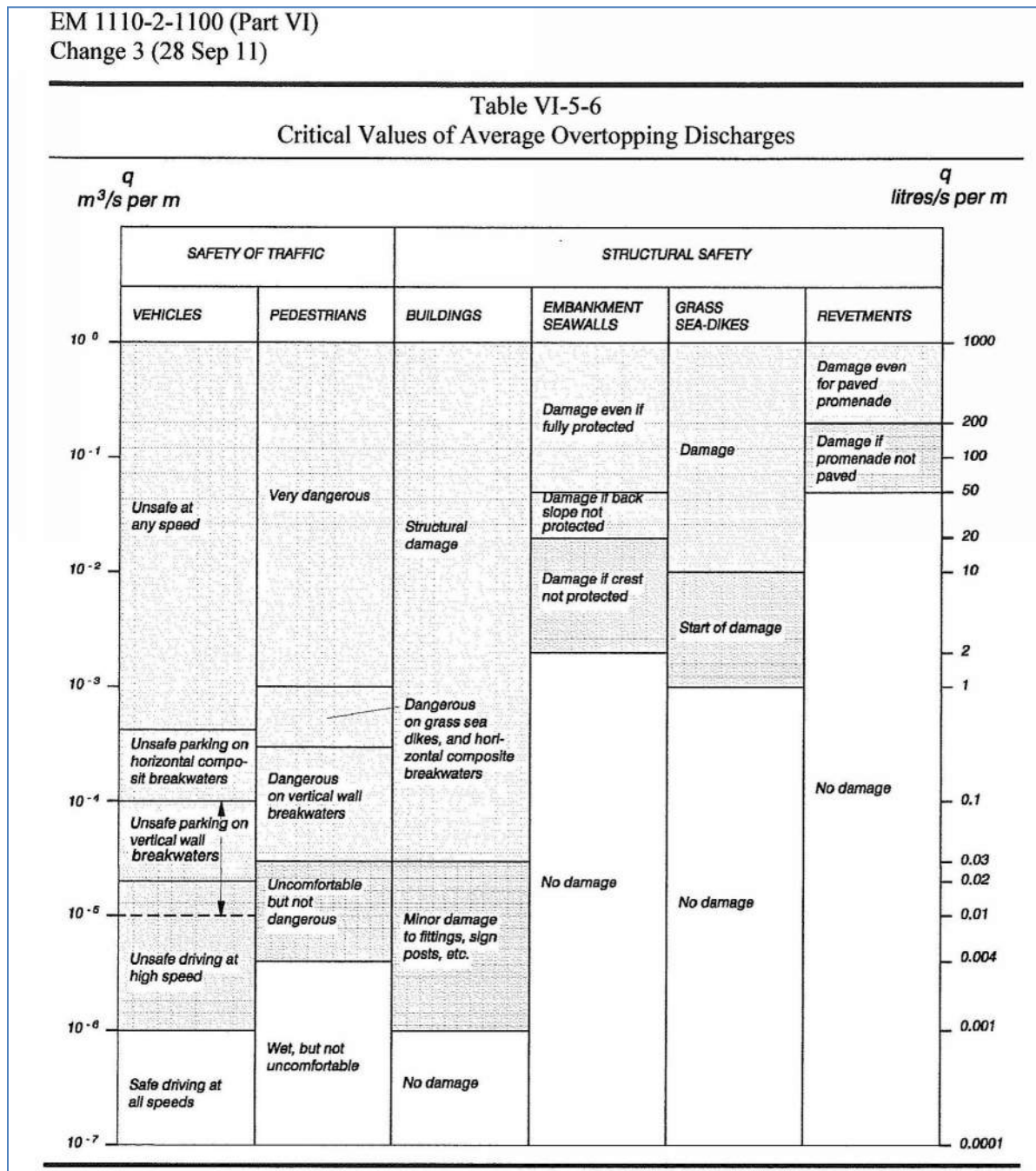

Revetment Armor Stone Sizing

Two methods to determine armor stone size requirements for dikes and revetments are presented in the CEM. This study compared the method of Van der Meer (1988) and the Hudson equation (1961).

The Hudson equation is based primarily on wave height and revetment slope and does not take account of the wave period. The method by Van der Meer includes impacts of core permeability,

limiting structural damage level (movement/loss of individual stones) and storm duration. For the purposes of this study, the following assumptions were used:

- Permeability of 0.1 (corresponding to an impermeable core).
- Structural damage level of 2 (corresponding to 0-5% allowable damage).
- Number of waves equal to 7000 (for wave period 12 secs = storm duration of 24 hours).

Both methods used the 1% annual chance open ocean storm wave + 2.9 foot return period estimated wave heights from Table E-5 below.

Table E-5 - Armor Stone Design Wave Conditions 100-year SWL + 2.9ft

Location	H _s feet	T _p secs
Nantasket Avenue North face	9.4	12.5

Both methods also assume a double armor layer (two stones thick) and a slope of 2 horizontal to 1 vertical. Sizing a revetment for two layers of stone increases the durability and protection by providing redundancy – if the outer layer is damaged, the second armor layer still protects the finer underlying material. Two layers of armor stone also offer additional benefit in absorbing wave energy by increasing the number of voids within the revetment and thereby creating a more permeable surface.

If a single layer of armor stone is used, the loss of a single stone can expose the smaller stone in the core and lead to more extensive deterioration of the revetment. If using a single layer, a more conservative approach should be used to estimate stone size to ensure durability. The wave heights from above gave individual armor stone weights as shown in Table E-6 below. These stone sizes are considered conservative because they use waves based on open ocean exposure and a water depth representative of end of design life.

Table E-6 Revetment Armor Individual Armor Stone Weight

	Individual Stone Size	
	Nantasket Avenue	
Method	Median Weight (tons)	D ₅₀ (feet)
Van der Meer	5	4.0
Hudson	5	3.95

Appendix F

Beach Grading Analysis

Memo

To: File
From: Blaze Engelman
c:
Date: November 2, 2021
Re: Sediment Grading Survey
Nantasket Avenue Seawall
Hull, MA
GEI Project No. 1900027

Site Description:

The Nantasket seawall sits on the northwestern coast of Hull Massachusetts protecting Nantasket Avenue. The beach below the seawall was composed of cobble and sand. At low tide, the beach was approximately 100 feet in width and became completely submerged at high tide. The beach slope was approximated at 1V : 20H. Different sediment classes were distinct across the width of the beach. Along the base of the wall, a 5 foot band of coarse sand material was pushed up against the wall. Past this 5 foot section, the beach transitioned and maintained a consistent look. Various sizes of gravel, cobble, and boulders were scattered along the top layer of the beach. In the lower elevation areas, small pools of water were typical.

Methods:

GEI performed a sediment grading survey on Wednesday, September 29, 2021. The survey investigated and sampled 5 locations along the beach at different elevations to determine an overall grading profile for the beach. Survey locations can be viewed in figure 1. Due to the large size of the individual pieces, a conventional grain size analysis cannot provide a proper representation of the material size distribution. An onsite procedure was followed to develop a representative size distribution. A 1 meter square area was investigated at each location using a quadrat as shown in the photos. Larger rocks were handpicked and weighed individually on a scale while anything under 3 inches in diameter was processed through sieves. The sieves were stacked in the following pattern: 3, 1.5, 1, 0.75, 0.5, 0.375 inch openings. The stack of sieves was shaken to allow sediment to fall and sort itself. The weight of the sediment on each sieve was recorded in a field tablet. The results were then converted into metric units and plotted on a logarithmic scale.



Figure 1: Overview of sediment sample locations along Nantasket Seawall Beach.

Sampling Logs:

Location #1

Sample location 1 was located 20 feet away from the seawall face on the western end of the seawall. The top layer of sediment consisted of a mixture of boulders, cobble and gravel. The top layer varied in depth depending on the size of the largest rocks. The second layer of sediment consisted of coarse sand, with gravel and cobble mixed. The second layer was approximately 6 inches in depth. The third and final layer of sediment discovered at the bottom of the sample location was brown silty coarse sand.



Figure 2a: Overview of sample location 1.



Figure 2b: View inside sample location 1.

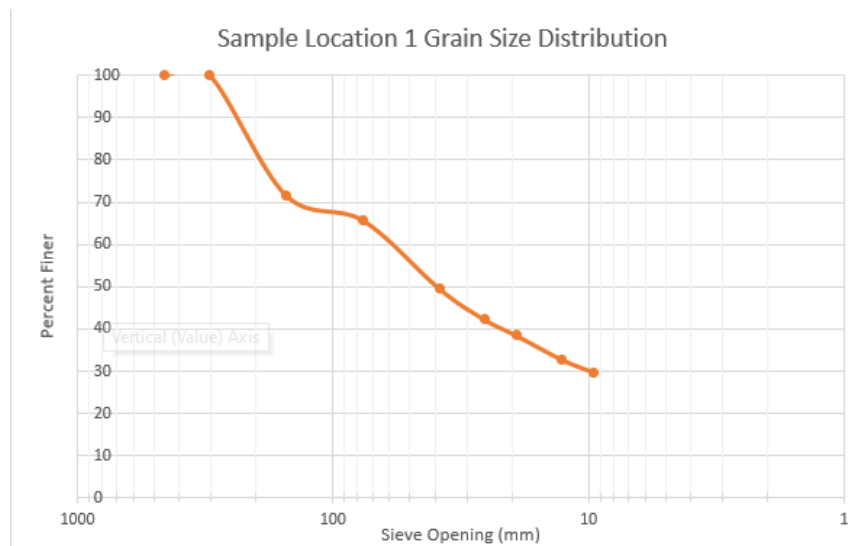

Figure 3: Grain size distribution from sediment sample location 1.

Location #2

Sample location 2 was located 50 feet from the seawall face. The exact location can be seen in figure 1. The top layer of sediment consisted of a mixture of boulders, cobble and gravel. The top layer was varied in depth depending on the size of the rocks. The second layer of sediment consisted of coarse sand, with gravel and cobble mixed. The second layer was approximately 8 inches in depth. The third and final layer of sediment discovered at the bottom of the sample location was coarse sand and small gravel with brown silt.



Figure 4a: Overview of sample location 2.



Figure 4b: View inside sample location 2.

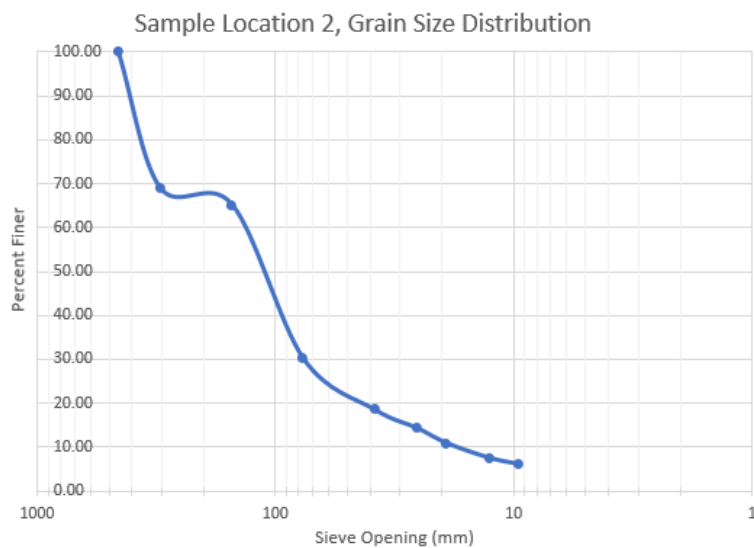

Figure 5: Grain size distribution from sediment sample location 2.

Location #3

Sample location 3 was located 5 feet from the seawall face. The exact location can be seen in figure 1. Location 3 only had one type of sediment layer. It consisted of mainly coarse sand with scattered cobble, and gravel mixed in.



Figure 6a: Overview of sample location 3.

Figure 6b: View inside sample location 3.

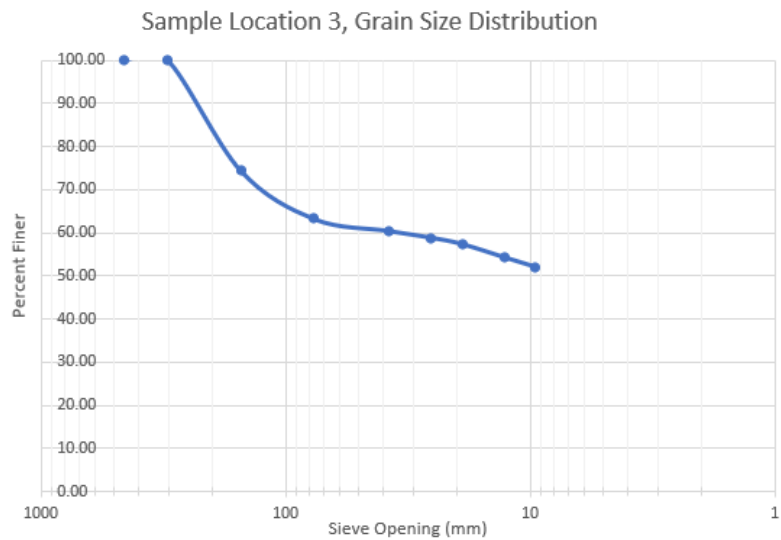

Figure 7: Grain size distribution from sediment sample location 3.

Location #4

Sample location 4 was located 50 feet from the seawall face. The exact location can be seen in figure 1. The top layer of sediment consisted of a mixture of boulders, cobble, and gravel. The top layer varied in depth depending on the size of the rocks. The second layer of sediment consisted of coarse sand, clay, and silt with gravel and cobble mixed. Due to the low elevation of location 4, water continually filled the sample location and depths of the sediment layers could not be viewed.



Figure 8a: Overview of sample location 4.



Figure 8b: View of sample location 4.

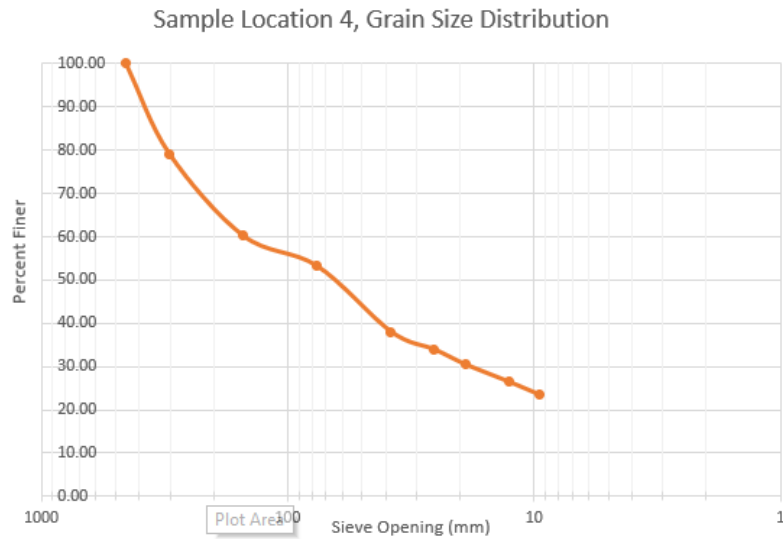

Figure 9: Grain size distribution from sediment sample location 4.

Location #5

Sample location 5 was located 20 feet away from the seawall face on the eastern end of the seawall. The top layer of sediment consisted of a mixture of boulders, cobble, and gravel. The top layer varied in depth depending on the size of the rocks. The second layer of sediment consisted of coarse sand, with gravel and cobble mixed and remained consistent until the bottom of the sample pit.



Figure 10a: Overview of sample location 5.



Figure 10b: View of sample location 5.

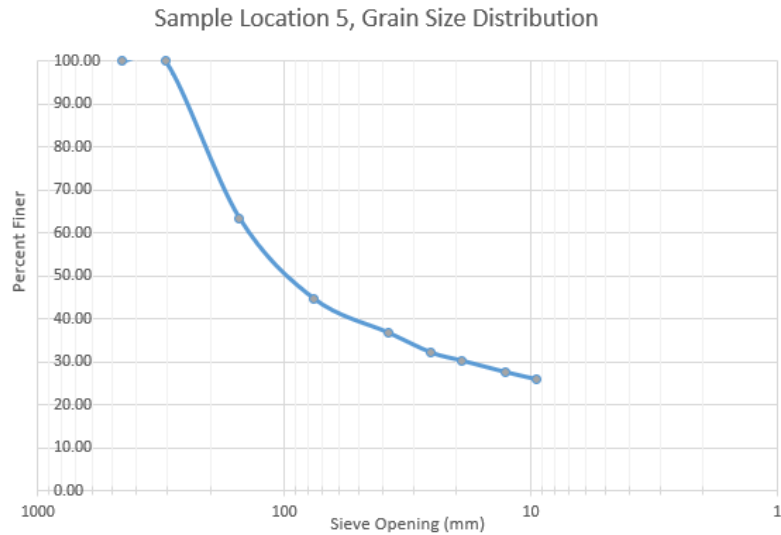

Figure 11: Grain size distribution from sediment sample location 5.

Results:

The Nantasket Seawall beach had three types of sediment layers. The majority of the beach had a top sediment layer which consisted of a mixture of boulders, cobble and gravel. This top layer varied in depth, but had an average of 6 inches. The second sediment layer was typically located directly under the top layer. The second layer consisted primarily of coarse sand with cobble and gravel pieces mixed in occasionally. This secondary layer varied in depth. Sample locations 2 and 4, located further from the face of the seawall had a thinner secondary layer than locations 1, 3, and 5. The third layer of sediment discovered in locations 2 and 4 consisted of a sand, clay and silt mixture that was colored brown. This third layer was located directly below the secondary layer.

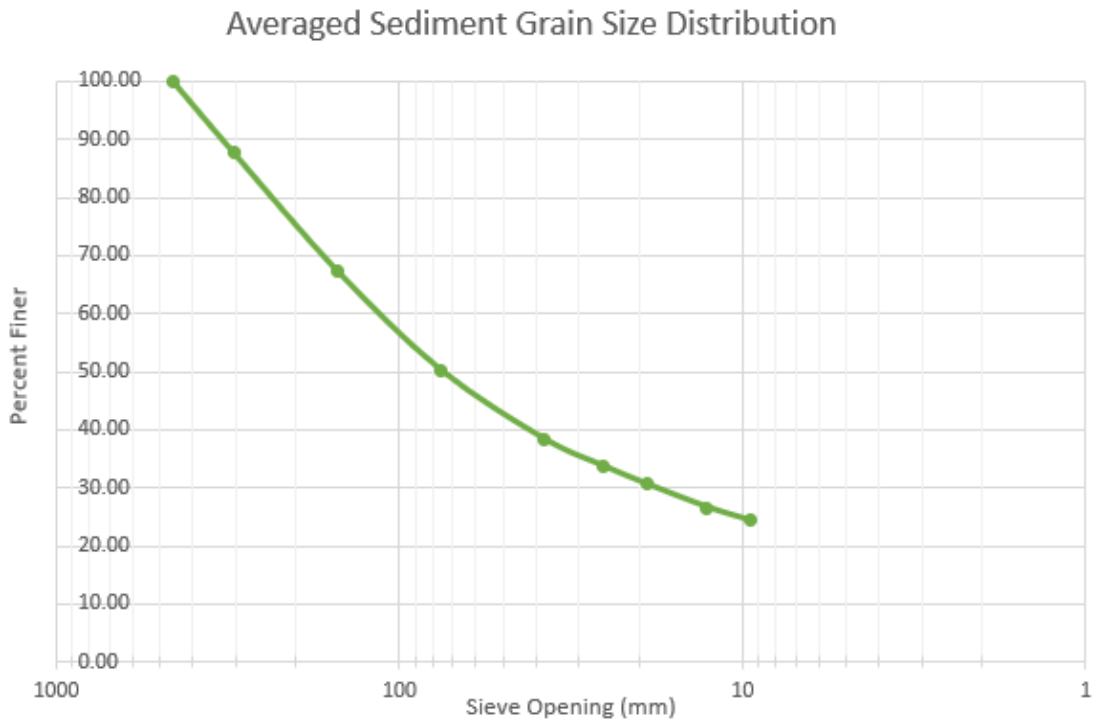

Figure 12: Averaged sediment distribution from all sample locations.

[author EBE : admin initials]
B:\Working\HULL MA, TOWN OF\1900027 Fitzpatrick Way Nantasket Ave Shoreline Protection\20 PRELIMINARY DESIGN\2_Coastal Analysis\Hull Sediment Investigation
2021.09.29\MEM Nantasket Seawall Grading 2021-12-15.docx

Appendix G

Stormwater Management Standards Documentation



Checklist for Stormwater Report

A. Introduction

Important: When filling out forms on the computer, use only the tab key to move your cursor - do not use the return key.



A Stormwater Report must be submitted with the Notice of Intent permit application to document compliance with the Stormwater Management Standards. The following checklist is NOT a substitute for the Stormwater Report (which should provide more substantive and detailed information) but is offered here as a tool to help the applicant organize their Stormwater Management documentation for their Report and for the reviewer to assess this information in a consistent format. As noted in the Checklist, the Stormwater Report must contain the engineering computations and supporting information set forth in Volume 3 of the [Massachusetts Stormwater Handbook](#). The Stormwater Report must be prepared and certified by a Registered Professional Engineer (RPE) licensed in the Commonwealth.

The Stormwater Report must include:

- The Stormwater Checklist completed and stamped by a Registered Professional Engineer (see page 2) that certifies that the Stormwater Report contains all required submittals.¹ This Checklist is to be used as the cover for the completed Stormwater Report.
- Applicant/Project Name
- Project Address
- Name of Firm and Registered Professional Engineer that prepared the Report
- Long-Term Pollution Prevention Plan required by Standards 4-6
- Construction Period Pollution Prevention and Erosion and Sedimentation Control Plan required by Standard 8²
- Operation and Maintenance Plan required by Standard 9

In addition to all plans and supporting information, the Stormwater Report must include a brief narrative describing stormwater management practices, including environmentally sensitive site design and LID techniques, along with a diagram depicting runoff through the proposed BMP treatment train. Plans are required to show existing and proposed conditions, identify all wetland resource areas, NRCS soil types, critical areas, Land Uses with Higher Potential Pollutant Loads (LUHPPL), and any areas on the site where infiltration rate is greater than 2.4 inches per hour. The Plans shall identify the drainage areas for both existing and proposed conditions at a scale that enables verification of supporting calculations.

As noted in the Checklist, the Stormwater Management Report shall document compliance with each of the Stormwater Management Standards as provided in the Massachusetts Stormwater Handbook. The soils evaluation and calculations shall be done using the methodologies set forth in Volume 3 of the Massachusetts Stormwater Handbook.

To ensure that the Stormwater Report is complete, applicants are required to fill in the Stormwater Report Checklist by checking the box to indicate that the specified information has been included in the Stormwater Report. If any of the information specified in the checklist has not been submitted, the applicant must provide an explanation. The completed Stormwater Report Checklist and Certification must be submitted with the Stormwater Report.

¹ The Stormwater Report may also include the Illicit Discharge Compliance Statement required by Standard 10. If not included in the Stormwater Report, the Illicit Discharge Compliance Statement must be submitted prior to the discharge of stormwater runoff to the post-construction best management practices.

² For some complex projects, it may not be possible to include the Construction Period Erosion and Sedimentation Control Plan in the Stormwater Report. In that event, the issuing authority has the discretion to issue an Order of Conditions that approves the project and includes a condition requiring the proponent to submit the Construction Period Erosion and Sedimentation Control Plan before commencing any land disturbance activity on the site.



Checklist for Stormwater Report

B. Stormwater Checklist and Certification

The following checklist is intended to serve as a guide for applicants as to the elements that ordinarily need to be addressed in a complete Stormwater Report. The checklist is also intended to provide conservation commissions and other reviewing authorities with a summary of the components necessary for a comprehensive Stormwater Report that addresses the ten Stormwater Standards.

Note: Because stormwater requirements vary from project to project, it is possible that a complete Stormwater Report may not include information on some of the subjects specified in the Checklist. If it is determined that a specific item does not apply to the project under review, please note that the item is not applicable (N.A.) and provide the reasons for that determination.

A complete checklist must include the Certification set forth below signed by the Registered Professional Engineer who prepared the Stormwater Report.

Registered Professional Engineer's Certification

I have reviewed the Stormwater Report, including the soil evaluation, computations, Long-term Pollution Prevention Plan, the Construction Period Erosion and Sedimentation Control Plan (if included), the Long-term Post-Construction Operation and Maintenance Plan, the Illicit Discharge Compliance Statement (if included) and the plans showing the stormwater management system, and have determined that they have been prepared in accordance with the requirements of the Stormwater Management Standards as further elaborated by the Massachusetts Stormwater Handbook. I have also determined that the information presented in the Stormwater Checklist is accurate and that the information presented in the Stormwater Report accurately reflects conditions at the site as of the date of this permit application.

Registered Professional Engineer Block and Signature

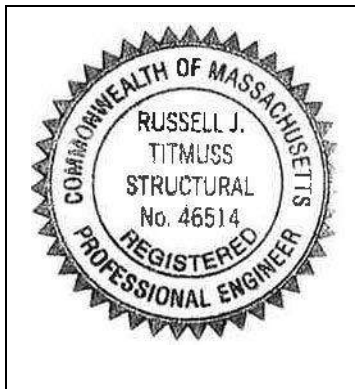

4/26/2022

Signature and Date

Checklist

Project Type: Is the application for new development, redevelopment, or a mix of new and redevelopment?

- New development
- Redevelopment
- Mix of New Development and Redevelopment



Checklist for Stormwater Report

Checklist (continued)

LID Measures: Stormwater Standards require LID measures to be considered. Document what environmentally sensitive design and LID Techniques were considered during the planning and design of the project:

- No disturbance to any Wetland Resource Areas
- Site Design Practices (e.g. clustered development, reduced frontage setbacks)
- Reduced Impervious Area (Redevelopment Only)
- Minimizing disturbance to existing trees and shrubs
- LID Site Design Credit Requested:
 - Credit 1
 - Credit 2
 - Credit 3
- Use of "country drainage" versus curb and gutter conveyance and pipe
- Bioretention Cells (includes Rain Gardens)
- Constructed Stormwater Wetlands (includes Gravel Wetlands designs)
- Treebox Filter
- Water Quality Swale
- Grass Channel
- Green Roof
- Other (describe): _____

Standard 1: No New Untreated Discharges

- No new untreated discharges
- Outlets have been designed so there is no erosion or scour to wetlands and waters of the Commonwealth
- Supporting calculations specified in Volume 3 of the Massachusetts Stormwater Handbook included.



Checklist for Stormwater Report

Checklist (continued)

Standard 2: Peak Rate Attenuation

- Standard 2 waiver requested because the project is located in land subject to coastal storm flowage and stormwater discharge is to a wetland subject to coastal flooding.
- Evaluation provided to determine whether off-site flooding increases during the 100-year 24-hour storm.
- Calculations provided to show that post-development peak discharge rates do not exceed pre-development rates for the 2-year and 10-year 24-hour storms. If evaluation shows that off-site flooding increases during the 100-year 24-hour storm, calculations are also provided to show that post-development peak discharge rates do not exceed pre-development rates for the 100-year 24-hour storm.

Standard 3: Recharge

- Soil Analysis provided.
- Required Recharge Volume calculation provided.
- Required Recharge volume reduced through use of the LID site Design Credits.
- Sizing the infiltration, BMPs is based on the following method: Check the method used.
 - Static
 - Simple Dynamic
 - Dynamic Field¹
- Runoff from all impervious areas at the site discharging to the infiltration BMP.
- Runoff from all impervious areas at the site is *not* discharging to the infiltration BMP and calculations are provided showing that the drainage area contributing runoff to the infiltration BMPs is sufficient to generate the required recharge volume.
- Recharge BMPs have been sized to infiltrate the Required Recharge Volume.
- Recharge BMPs have been sized to infiltrate the Required Recharge Volume *only* to the maximum extent practicable for the following reason:
 - Site is comprised solely of C and D soils and/or bedrock at the land surface
 - M.G.L. c. 21E sites pursuant to 310 CMR 40.0000
 - Solid Waste Landfill pursuant to 310 CMR 19.000
 - Project is otherwise subject to Stormwater Management Standards only to the maximum extent practicable.
- Calculations showing that the infiltration BMPs will drain in 72 hours are provided.
- Property includes a M.G.L. c. 21E site or a solid waste landfill and a mounding analysis is included.

¹ 80% TSS removal is required prior to discharge to infiltration BMP if Dynamic Field method is used.



Checklist for Stormwater Report

Checklist (continued)

Standard 3: Recharge (continued)

- The infiltration BMP is used to attenuate peak flows during storms greater than or equal to the 10-year 24-hour storm and separation to seasonal high groundwater is less than 4 feet and a mounding analysis is provided.
- Documentation is provided showing that infiltration BMPs do not adversely impact nearby wetland resource areas.

Standard 4: Water Quality **Project complies to max extent practicable - see narrative**

The Long-Term Pollution Prevention Plan typically includes the following:

- Good housekeeping practices;
 - Provisions for storing materials and waste products inside or under cover;
 - Vehicle washing controls;
 - Requirements for routine inspections and maintenance of stormwater BMPs;
 - Spill prevention and response plans;
 - Provisions for maintenance of lawns, gardens, and other landscaped areas;
 - Requirements for storage and use of fertilizers, herbicides, and pesticides;
 - Pet waste management provisions;
 - Provisions for operation and management of septic systems;
 - Provisions for solid waste management;
 - Snow disposal and plowing plans relative to Wetland Resource Areas;
 - Winter Road Salt and/or Sand Use and Storage restrictions;
 - Street sweeping schedules;
 - Provisions for prevention of illicit discharges to the stormwater management system;
 - Documentation that Stormwater BMPs are designed to provide for shutdown and containment in the event of a spill or discharges to or near critical areas or from LUHPPL;
 - Training for staff or personnel involved with implementing Long-Term Pollution Prevention Plan;
 - List of Emergency contacts for implementing Long-Term Pollution Prevention Plan.
- A Long-Term Pollution Prevention Plan is attached to Stormwater Report and is included as an attachment to the Wetlands Notice of Intent.
 - Treatment BMPs subject to the 44% TSS removal pretreatment requirement and the one inch rule for calculating the water quality volume are included, and discharge:
 - is within the Zone II or Interim Wellhead Protection Area
 - is near or to other critical areas
 - is within soils with a rapid infiltration rate (greater than 2.4 inches per hour)
 - involves runoff from land uses with higher potential pollutant loads.
 - The Required Water Quality Volume is reduced through use of the LID site Design Credits.
 - Calculations documenting that the treatment train meets the 80% TSS removal requirement and, if applicable, the 44% TSS removal pretreatment requirement, are provided.



Checklist for Stormwater Report

Checklist (continued)

Standard 4: Water Quality (continued)

- The BMP is sized (and calculations provided) based on:
 - The ½" or 1" Water Quality Volume or
 - The equivalent flow rate associated with the Water Quality Volume and documentation is provided showing that the BMP treats the required water quality volume.
- The applicant proposes to use proprietary BMPs, and documentation supporting use of proprietary BMP and proposed TSS removal rate is provided. This documentation may be in the form of the propriety BMP checklist found in Volume 2, Chapter 4 of the Massachusetts Stormwater Handbook and submitting copies of the TARP Report, STEP Report, and/or other third party studies verifying performance of the proprietary BMPs.
- A TMDL exists that indicates a need to reduce pollutants other than TSS and documentation showing that the BMPs selected are consistent with the TMDL is provided.

Standard 5: Land Uses With Higher Potential Pollutant Loads (LUHPPLs)

- The NPDES Multi-Sector General Permit covers the land use and the Stormwater Pollution Prevention Plan (SWPPP) has been included with the Stormwater Report.
- The NPDES Multi-Sector General Permit covers the land use and the SWPPP will be submitted **prior to** the discharge of stormwater to the post-construction stormwater BMPs.
- The NPDES Multi-Sector General Permit does **not** cover the land use.
- LUHPPLs are located at the site and industry specific source control and pollution prevention measures have been proposed to reduce or eliminate the exposure of LUHPPLs to rain, snow, snow melt and runoff, and been included in the long term Pollution Prevention Plan.
- All exposure has been eliminated.
- All exposure has **not** been eliminated and all BMPs selected are on MassDEP LUHPPL list.
- The LUHPPL has the potential to generate runoff with moderate to higher concentrations of oil and grease (e.g. all parking lots with >1000 vehicle trips per day) and the treatment train includes an oil grit separator, a filtering bioretention area, a sand filter or equivalent.

Standard 6: Critical Areas **Project complies to max extent practicable - see narrative**

- The discharge is near or to a critical area and the treatment train includes only BMPs that MassDEP has approved for stormwater discharges to or near that particular class of critical area.
- Critical areas and BMPs are identified in the Stormwater Report.



Checklist for Stormwater Report

Checklist (continued)

Standard 7: Redevelopments and Other Projects Subject to the Standards only to the maximum extent practicable

- The project is subject to the Stormwater Management Standards only to the maximum Extent Practicable as a:
 - Limited Project
 - Small Residential Projects: 5-9 single family houses or 5-9 units in a multi-family development provided there is no discharge that may potentially affect a critical area.
 - Small Residential Projects: 2-4 single family houses or 2-4 units in a multi-family development with a discharge to a critical area
 - Marina and/or boatyard provided the hull painting, service and maintenance areas are protected from exposure to rain, snow, snow melt and runoff
 - Bike Path and/or Foot Path
 - Redevelopment Project
 - Redevelopment portion of mix of new and redevelopment.
- Certain standards are not fully met (Standard No. 1, 8, 9, and 10 must always be fully met) and an explanation of why these standards are not met is contained in the Stormwater Report.
- The project involves redevelopment and a description of all measures that have been taken to improve existing conditions is provided in the Stormwater Report. The redevelopment checklist found in Volume 2 Chapter 3 of the Massachusetts Stormwater Handbook may be used to document that the proposed stormwater management system (a) complies with Standards 2, 3 and the pretreatment and structural BMP requirements of Standards 4-6 to the maximum extent practicable and (b) improves existing conditions.

Standard 8: Construction Period Pollution Prevention and Erosion and Sedimentation Control

A Construction Period Pollution Prevention and Erosion and Sedimentation Control Plan must include the following information:

- Narrative;
 - Construction Period Operation and Maintenance Plan;
 - Names of Persons or Entity Responsible for Plan Compliance;
 - Construction Period Pollution Prevention Measures;
 - Erosion and Sedimentation Control Plan Drawings;
 - Detail drawings and specifications for erosion control BMPs, including sizing calculations;
 - Vegetation Planning;
 - Site Development Plan;
 - Construction Sequencing Plan;
 - Sequencing of Erosion and Sedimentation Controls;
 - Operation and Maintenance of Erosion and Sedimentation Controls;
 - Inspection Schedule;
 - Maintenance Schedule;
 - Inspection and Maintenance Log Form.
- A Construction Period Pollution Prevention and Erosion and Sedimentation Control Plan containing the information set forth above has been included in the Stormwater Report.



Checklist for Stormwater Report

Checklist (continued)

Standard 8: Construction Period Pollution Prevention and Erosion and Sedimentation Control (continued)

- The project is highly complex and information is included in the Stormwater Report that explains why it is not possible to submit the Construction Period Pollution Prevention and Erosion and Sedimentation Control Plan with the application. A Construction Period Pollution Prevention and Erosion and Sedimentation Control has **not** been included in the Stormwater Report but will be submitted **before** land disturbance begins.
- The project is **not** covered by a NPDES Construction General Permit.
- The project is covered by a NPDES Construction General Permit and a copy of the SWPPP is in the Stormwater Report.
- The project is covered by a NPDES Construction General Permit but no SWPPP been submitted. The SWPPP will be submitted BEFORE land disturbance begins.

Standard 9: Operation and Maintenance Plan

- The Post Construction Operation and Maintenance Plan is included in the Stormwater Report and includes the following information:
 - Name of the stormwater management system owners;
 - Party responsible for operation and maintenance;
 - Schedule for implementation of routine and non-routine maintenance tasks;
 - Plan showing the location of all stormwater BMPs maintenance access areas;
 - Description and delineation of public safety features;
 - Estimated operation and maintenance budget; and
 - Operation and Maintenance Log Form.
- The responsible party is **not** the owner of the parcel where the BMP is located and the Stormwater Report includes the following submissions:
 - A copy of the legal instrument (deed, homeowner's association, utility trust or other legal entity) that establishes the terms of and legal responsibility for the operation and maintenance of the project site stormwater BMPs;
 - A plan and easement deed that allows site access for the legal entity to operate and maintain BMP functions.

Standard 10: Prohibition of Illicit Discharges

- The Long-Term Pollution Prevention Plan includes measures to prevent illicit discharges;
- An Illicit Discharge Compliance Statement is attached;
- NO Illicit Discharge Compliance Statement is attached but will be submitted **prior to** the discharge of any stormwater to post-construction BMPs.

Appendix H

Long Term Pollution Prevention and Stormwater Operation and Maintenance Plan

1. INTRODUCTION

The purpose of this document is to specify the pollution prevention measures and stormwater management system operation and maintenance for the Nantasket Avenue Seawall project site. The Responsible Party indicated below shall implement the management practices outlined in this document and proactively conduct operations at the project site in an environmentally responsible manner. Compliance with this Manual does not in any way dismiss the responsible party, owner, property manager, or occupants from compliance with other applicable federal, state or local laws.

Responsible Party: Philip Lemnios
Town Manager
Town of Hull
253 Atlantic Avenue
Hull, MA 02045
Office: (781) 925-2000

This Document has been prepared in compliance with Standards 4 and 9 of the 2008 Massachusetts Department of Environmental Protection (MassDEP) Stormwater Management Standards, which state:

Standard 4:

The Long Term Pollution Prevention Plan shall include the proper procedures for the following:

- Good housekeeping
- Storing materials and waste products inside or under cover
- Routine inspections of stormwater best management practices
- Spill prevention and response
- Proper management of deicing chemicals and snow

Standard 9:

The Long-Term Operation and Maintenance Plan shall at a minimum include:

- Stormwater management system(s) owner(s)
- The party or parties responsible for operation and maintenance, including how future property owners shall be notified of the presence of the stormwater management system and the requirement for operation and maintenance
- The routine and non-routine maintenance tasks to be undertaken after construction is complete and a schedule for implementing those tasks
- A plan that is drawn to scale and shows the location of all stormwater BMPs in each treatment train along with the discharge point
- A description of public safety features
- An estimated operations and maintenance budget

2. Long Term Pollution Prevention Plan

The Responsible Party shall implement the following good housekeeping procedures at the project site to reduce the possibility of accidental releases and to reduce safety hazards.

2.1. Storage of Hazardous Materials and Waste Products

No hazardous materials or waste products will be stored at the site.

2.2. Spill Prevention and Response

Implement spill response procedures for releases of significant materials such as fuels, oils, or chemical materials onto the ground or other area that could reasonably be expected to discharge to surface or groundwater.

- For minor spills, keep fifty (50) gallon spill control kits and Speedy Dry at all shop and work areas.
- Immediately contact applicable Federal, State, and local agencies for reportable quantities as required by law.
- Immediately perform applicable containment and cleanup procedures following a spill release. Promptly remove and dispose of all material collected during the response in accordance with Federal, State and local requirements. A licensed emergency response contractor may be required to assist in cleanup of releases depending on the amount of the release, and the ability of the Contractor to perform the required response.
- Reportable quantities of chemicals, fuels, or oils are established under the Clean Water Act and enforced through Massachusetts Department of Environmental Protection (DEP).
- Floating booms.

2.3. Minimize Soil Erosion

Soil erosion facilitates mechanical transport of nutrients, pathogens, and organic matter to surface water bodies. Repair all areas where erosion is occurring throughout the project site. Stabilize bare soil with riprap, seed, mulch, or vegetation as appropriate.

2.4. Management of Deicing Chemicals and Snow

All contractors and employees engaged in snow plowing and deicing shall be made fully aware of the requirements of this section.

No road salt (sodium chloride) or other de-icing chemicals shall be stored on-site.

During typical snow plowing operations, snow shall be pushed to the designated snow removal areas. Snow shall not be stockpiled in wetland resource areas or the 100-foot Buffer Zone. In severe conditions where snow cannot be stockpiled on site, the snow shall be removed from the site and properly disposed of in accordance with DEP Guideline BRP601-01.

Use of sand is permitted only for impervious roadways and parking areas. If sand is applied, the snow plowed from impervious areas shall not be stored on porous asphalt.

Before winter begins, the property owner and the contractor shall review snow plowing, deicing, and stockpiling procedures. Areas designated for stockpiling should be cleaned of any debris. Street and parking lot sweeping should be followed in accordance with the Operation and Maintenance Plan.

3. STORMWATER MANAGEMENT SYSTEM OPERATION AND MAINTENANCE PLAN

3.1. Introduction

This Operation and Maintenance Plan (O&M Plan) is required under Standard 9 of the 2008 MassDEP Stormwater Handbook to provide best management practices for implementing maintenance activities for the stormwater management system in a manner that minimizes impacts to wetland resource areas.

The Owner shall implement this O&M Plan and proactively conduct operations at the site in an environmentally responsible manner. Compliance with this O&M Plan does not in any way dismiss the Owner from compliance with other applicable Federal, State or local laws.

Routine maintenance during construction and post-development phases of the project, as defined in the Operation and Maintenance Plan, shall be permitted without amendment to the Order of Conditions. A continuing condition in the Certificate of Compliance shall ensure that maintenance can be performed without triggering further filings under the Wetlands Protection Act.

All stormwater best management practices (BMPs) shall be operated and maintained in accordance with the design plans and the Operation and Maintenance Plan approved by the issuing authority. The Owner shall:

- Maintain an operation and maintenance log for the last three years, including inspections, repairs, replacement and disposal (for disposal the log shall indicate the type of material and the disposal location). This is a rolling log in which the responsible party records all operation and maintenance activities for the past three years.
- Make this log available to MassDEP and the Conservation Commission upon request; and
- Allow members and agents of the MassDEP and the Conservation Commission to enter and inspect the premises to evaluate and ensure that the Owner complies with the Operation and Maintenance requirements for each BMP.

3.2. Stormwater Operation and Maintenance Requirements

Inspect and maintain the stormwater management system as directed below.

3.3. Street Sweeping

Perform street sweeping at least twice per year, whenever there is significant debris present on the road. Street sweeping shall occur in the spring and fall. Sweepings shall be handled and disposed of in accordance with state and local regulations.

3.4. Repair of the Stormwater Management System

The stormwater management system shall be maintained. The repair of any component of the system shall be made as soon as possible to prevent any potential pollutants including silt from entering resource areas.

3.5. Reporting

The Owner shall maintain a record of system inspections and maintenance (per this Plan) and submit a yearly report to the Conservation Commission.

NANTASKET AVENUE SEAWALL REPLACEMENT

NANTASKET AVENUE
HULL, MA 02045

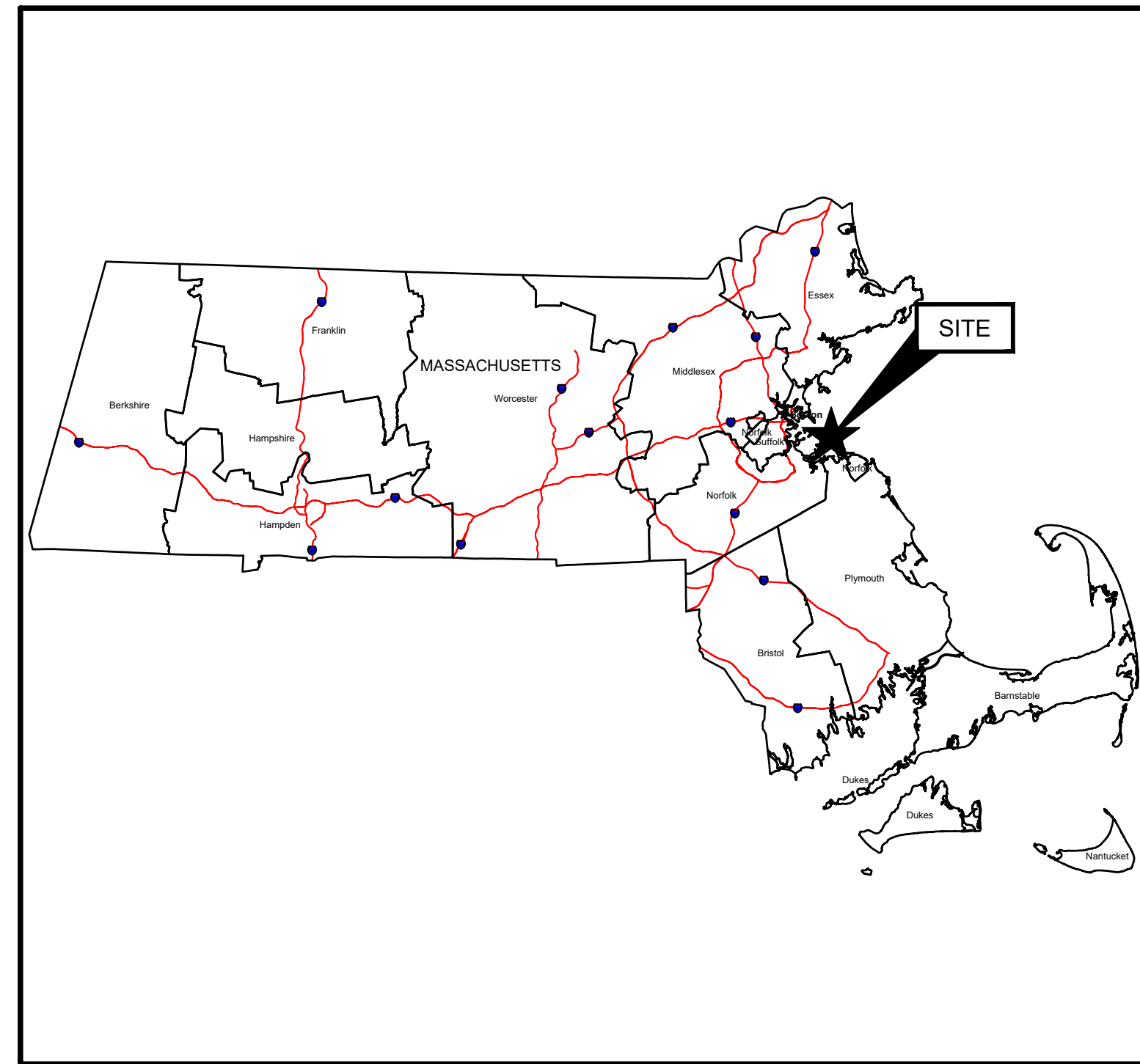

STATE or COUNTY MAP
(NOT TO SCALE)

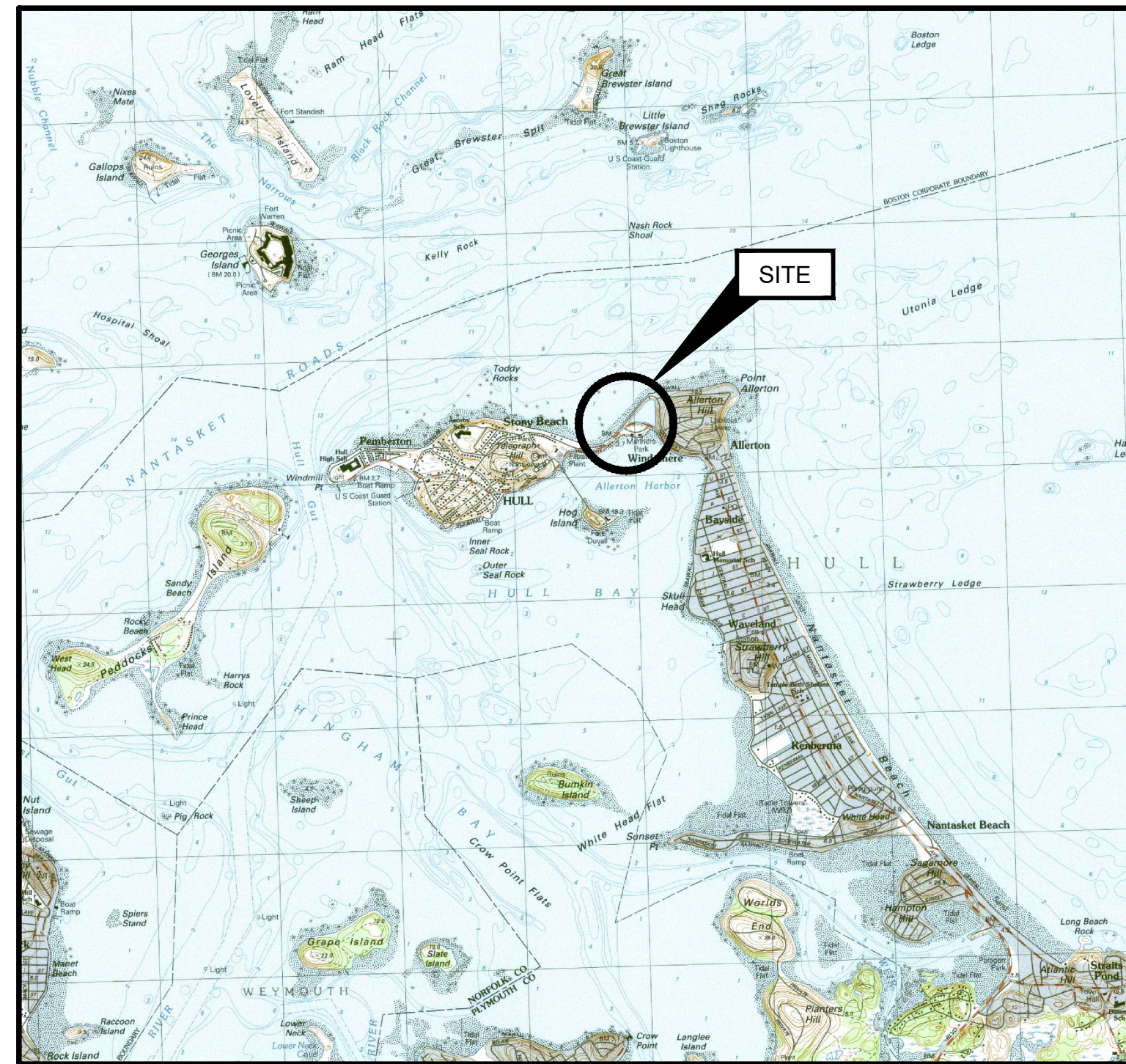

SITE LOCATION MAP
(NOT TO SCALE)

PREPARED FOR:

TOWN OF HULL
253 ATLANTIC AVENUE
HULL, MA 02045
(781)925-2000

PREPARED BY:

GEI CONSULTANTS, INC.
124 GROVE STREET
FRANKLIN, MA 02038
(774)277-6001



FOR PERMITS ONLY
NOT FOR CONSTRUCTION

THIS DOCUMENT, AND THE IDEAS AND DESIGNS INCORPORATED HEREIN, IS AN INSTRUMENT OF PROFESSIONAL SERVICE, IS THE PROPERTY OF GEI CONSULTANTS AND IS NOT TO BE USED, IN WHOLE OR IN PART, FOR ANY OTHER PROJECT WITHOUT THE WRITTEN AUTHORIZATION OF GEI CONSULTANTS.

GEI PROJECT NO. 1900027

				DWG. NO.
				G-001
				SHEET NO.
				-
NO.	DATE	ISSUE/REVISION	APP	
0	12/09/2021	ENF DRAWINGS		

MASSACHUSETTS BAY

FEMA VE ZONE EL. 21 NAVD
(EL. +26.2 MLW)

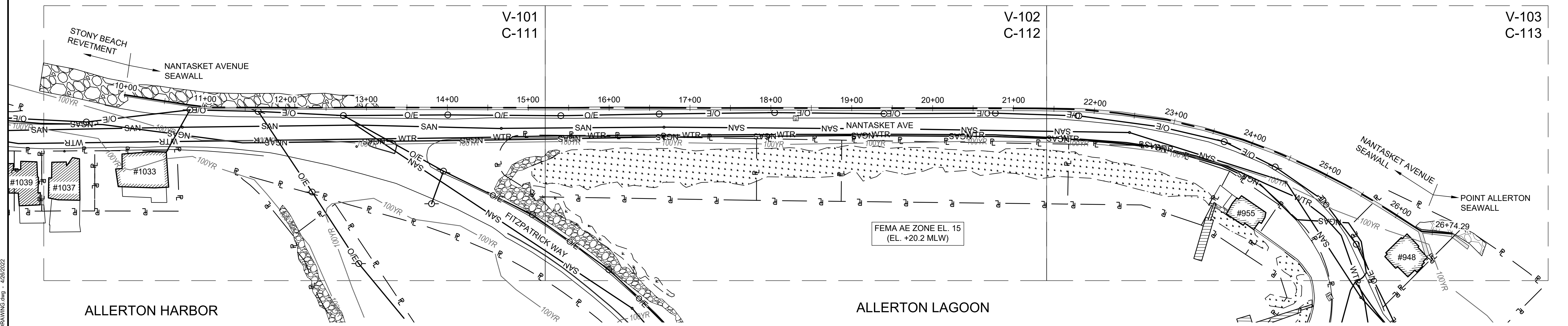

ALLERTON HARBOR

ALLERTON LAGOON

LEGEND

- 100YR - FEMA FLOOD LINE
- PROPERTY LINE
- GAS LINE
- OVERHEAD POWER LINES
- SEWER LINE
- WATER LINE
- UTILITY POLE
- CATCH BASIN
- SEWER MANHOLE
- STORM DRAIN MANHOLE
- SALT MARSH
- RIP RAP
- RIP RAP (LAGOON)

TIDAL DATUMS

HTL	+11.6
MHW	+ 9.1
NAVD88	+ 5.2
MLW	0.0

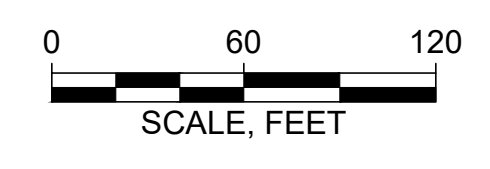

Attention:
0 1"
If this scale bar does not measure 1" then drawing is not original scale.

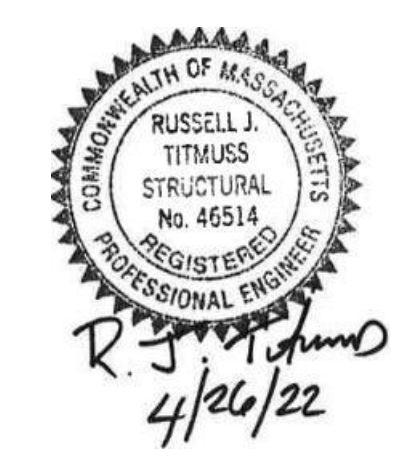

Designed: AJG
Drawn: JSF
Checked: RJT
Approved: RJT
P.E. No:
GEI Project 1900027



TOWN OF HULL
253 ATLANTIC AVE
HULL, MA 02045

NANTASKET AVENUE SEAWALL

NANTASKET AVENUE
HULL, MA 02045

NO	DATE	ISSUE/REVISION	APP
0	12/09/2021	ENF DRAWINGS	

SHEET NAME
OVERALL SITE PLAN & SHEET LAYOUT

SHEET NO.
G-101

FOR PERMITS ONLY
NOT FOR CONSTRUCTION

TITMUS, RUSSELL J. WokingHULL, MA, TOWN OF HULL, MA, 253 ATLANTIC AVE, HULL, MA 02045, SHEET LAYOUT DRAWING.dwg - 4/26/2022

FITZGERALD, JAMISON, B. Working: HULL, MA, TOWN OF 1900027 Fitzpatrick Way Nantasket Ave Shoreline Protection 03_CADDesign\Working\19-01 EXISTING CONDITIONS.dwg - 4/26/2022

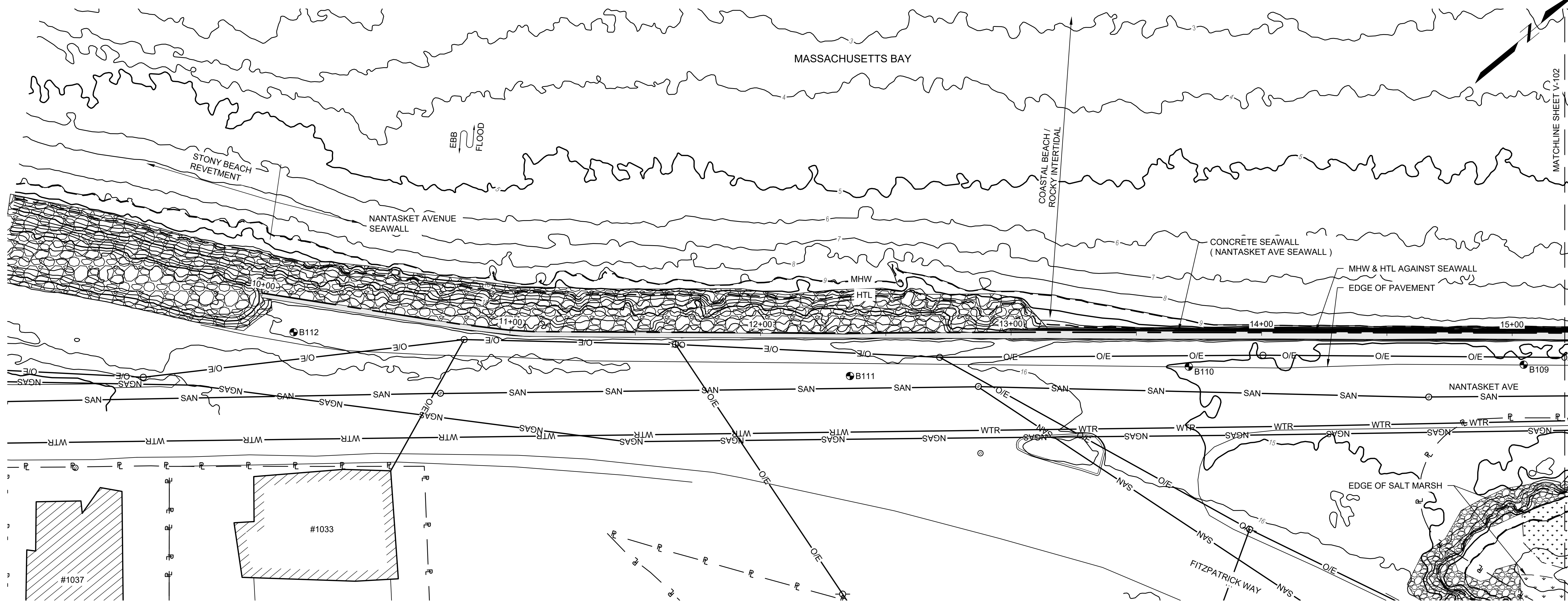

- NOTES:
1. PLAN BASED ON SURVEY CONDUCTED BY SUAS (SMALL UNMANNED AIRCRAFT SYSTEM) BY GEI CONSULTANTS, INC. ON APRIL 11, 2019 AND CAN ONLY REFLECT CONDITIONS AS THEY EXISTED ON THAT DAY.
 2. VERTICAL DATUM IS SET TO MEAN LOW WATER (MLW).
 3. BENCHMARK USED IN BENCHMARK 85B WITH AN ESTABLISHED HEIGHT OF 12.131' (NGVD29) LOCATED AT N 2937216.57 E 819977.16.
 4. THE ENTIRE ZONE OF WORK IS WITHIN AREA DESIGNATED BARRIER BEACH.
 5. THE ENTIRE ZONE OF WORK IS WITHIN AREA DESIGNATED LAND SUBJECT TO COASTAL STORM FLOWAGE.
 6. AREA ON THE BEACH NORTH OF THE SEAWALL IS MAPPED AS AREA SUITABLE FOR SHELLFISH AND DESIGNATED AS SUITABLE FOR BLUE MUSSELS. MUSSEL SHELLS BUT NO LIVE MUSSELS WERE OBSERVED CLOSE TO THE EXISTING SEAWALL AND EXISTING REVETMENT.

FOR PERMITS ONLY
NOT FOR CONSTRUCTION

TIDAL DATUMS	
HTL	+11.6
MHW	+ 9.1
NAVD88	+ 5.2
MLW	0.0



Attention:
0 1"
If this scale bar does not measure 1" then drawing is not original scale.

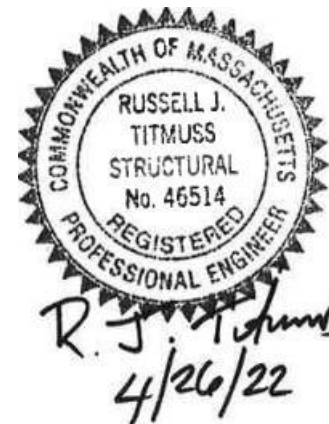

Designed: AJG
Drawn: JSF
Checked: RJT
Approved: RJT
P.E. No:
GEI Project 1900027



TOWN OF HULL
253 ATLANTIC AVE
HULL, MA 02045

NANTASKET AVENUE SEAWALL

NANTASKET AVENUE
HULL, MA 02045

NO	DATE	ISSUE/REVISION	APP
0	12/09/2021	ENF DRAWINGS	

SHEET NAME
EXISTING CONDITIONS SHEET 1 OF 3

SHEET NO.
V-101

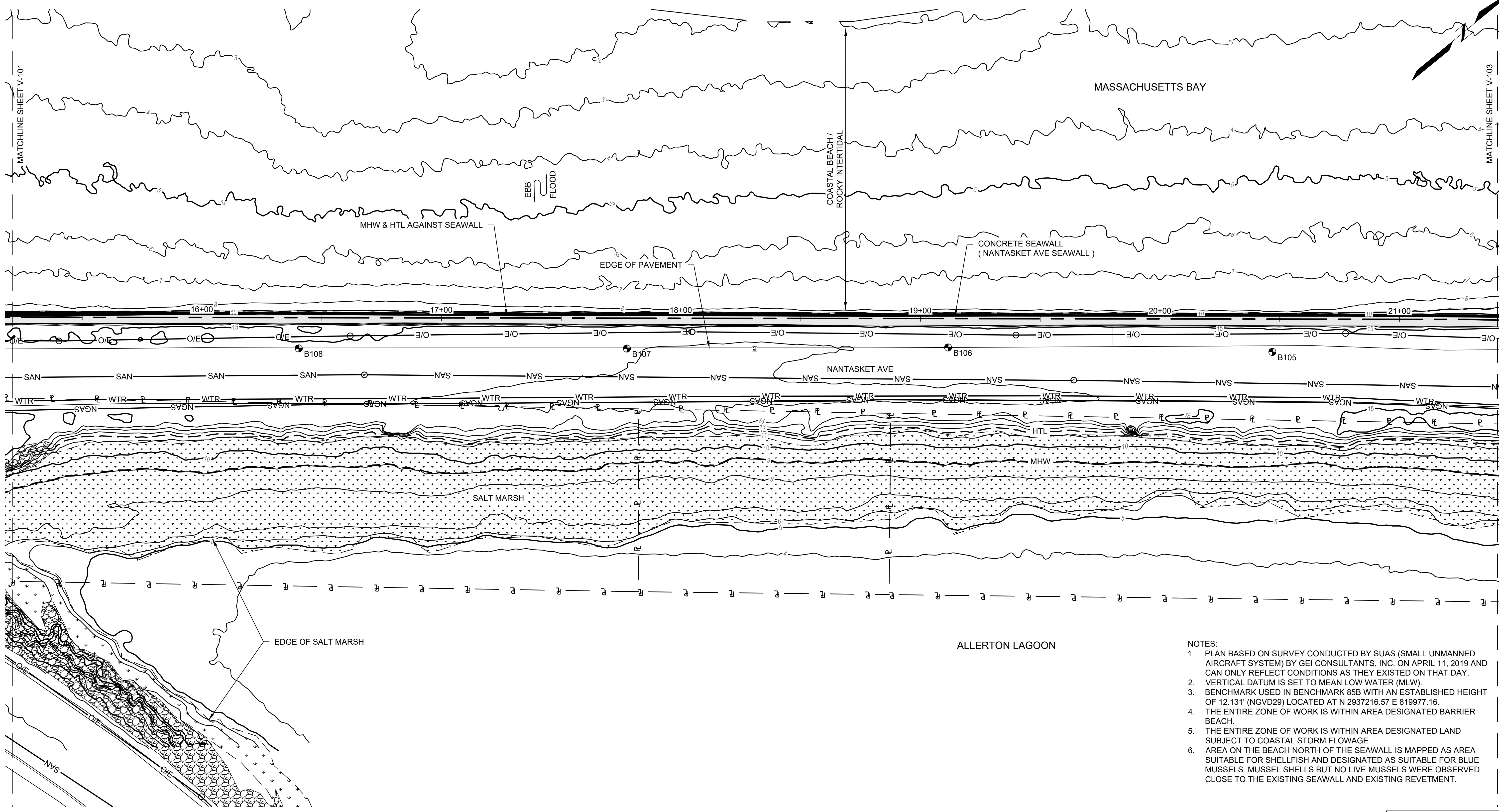

- NOTES:
1. PLAN BASED ON SURVEY CONDUCTED BY SUAS (SMALL UNMANNED AIRCRAFT SYSTEM) BY GEI CONSULTANTS, INC. ON APRIL 11, 2019 AND CAN ONLY REFLECT CONDITIONS AS THEY EXISTED ON THAT DAY.
 2. VERTICAL DATUM IS SET TO MEAN LOW WATER (MLW).
 3. BENCHMARK USED IN BENCHMARK 85B WITH AN ESTABLISHED HEIGHT OF 12.131' (NGVD29) LOCATED AT N 2937216.57 E 819977.16.
 4. THE ENTIRE ZONE OF WORK IS WITHIN AREA DESIGNATED BARRIER BEACH.
 5. THE ENTIRE ZONE OF WORK IS WITHIN AREA DESIGNATED LAND SUBJECT TO COASTAL STORM FLOWAGE.
 6. AREA ON THE BEACH NORTH OF THE SEAWALL IS MAPPED AS AREA SUITABLE FOR SHELLFISH AND DESIGNATED AS SUITABLE FOR BLUE MUSSELS. MUSSEL SHELLS BUT NO LIVE MUSSELS WERE OBSERVED CLOSE TO THE EXISTING SEAWALL AND EXISTING REVETMENT.

FOR PERMITS ONLY
NOT FOR CONSTRUCTION

TIDAL DATUMS	
HTL	+11.6
MHW	+ 9.1
NAVD88	+ 5.2
MLW	0.0



Attention:
0 1"
If this scale bar does not measure 1" then drawing is not original scale.



Designed: AJG
Drawn: JSF
Checked: RJT
Approved: RJT
P.E. No:
GEI Project 1900027



TOWN OF HULL
253 ATLANTIC AVE
HULL, MA 02045

NANTASKET AVENUE SEAWALL

NANTASKET AVENUE
HULL, MA 02045

NO	DATE	ISSUE/REVISION	APP
0	12/09/2021	ENF DRAWINGS	

SHEET NAME
EXISTING CONDITIONS SHEET 2 OF 3

SHEET NO.
V-102

FITZGERALD, JAMISON, B:\Working\HULL, MA, TOWN OF\1900027\Fig\Plan\1900027_Fig\Plan\1900027_02_EXISTING CONDITIONS.dwg - 4/26/2022

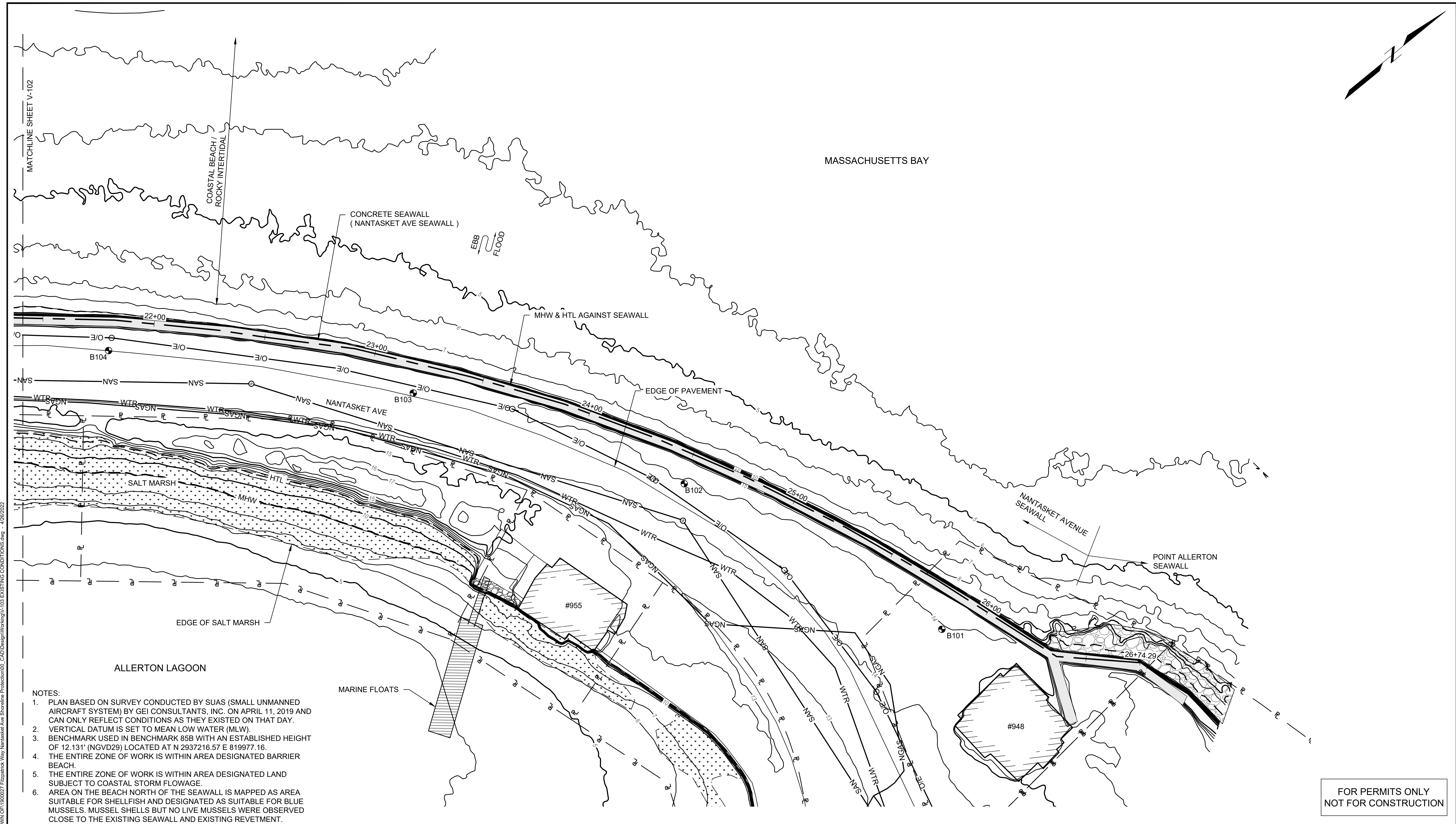
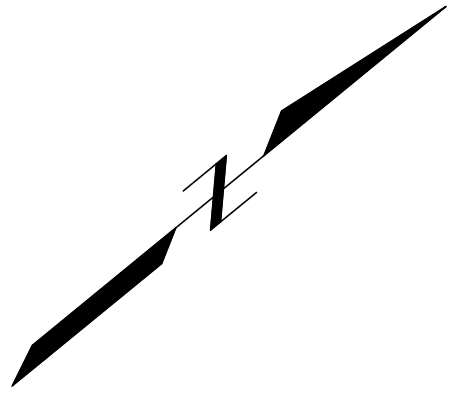

- NOTES:
1. PLAN BASED ON SURVEY CONDUCTED BY SUAS (SMALL UNMANNED AIRCRAFT SYSTEM) BY GEI CONSULTANTS, INC. ON APRIL 11, 2019 AND CAN ONLY REFLECT CONDITIONS AS THEY EXISTED ON THAT DAY.
 2. VERTICAL DATUM IS SET TO MEAN LOW WATER (MLW).
 3. BENCHMARK USED IN BENCHMARK 85B WITH AN ESTABLISHED HEIGHT OF 12.131' (NGVD29) LOCATED AT N 2937216.57 E 819977.16.
 4. THE ENTIRE ZONE OF WORK IS WITHIN AREA DESIGNATED BARRIER BEACH.
 5. THE ENTIRE ZONE OF WORK IS WITHIN AREA DESIGNATED LAND SUBJECT TO COASTAL STORM FLOWAGE.
 6. AREA ON THE BEACH NORTH OF THE SEAWALL IS MAPPED AS AREA SUITABLE FOR SHELLFISH AND DESIGNATED AS SUITABLE FOR BLUE MUSSELS. MUSSEL SHELLS BUT NO LIVE MUSSELS WERE OBSERVED CLOSE TO THE EXISTING SEAWALL AND EXISTING REVETMENT.

FOR PERMITS ONLY
NOT FOR CONSTRUCTION

TIDAL DATUMS	
HTL	+11.6
MHW	+ 9.1
NAVD88	+ 5.2
MLW	0.0



Attention:
0 1"
If this scale bar does not measure 1" then drawing is not original scale.



Designed: AJG
 Drawn: JSF
 Checked: RJT
 Approved: RJT
 P.E. No:
 GEI Project 1900027



TOWN OF HULL
253 ATLANTIC AVE
HULL, MA 02045

NANTASKET AVENUE SEAWALL

NANTASKET AVENUE
HULL, MA 02045

NO	DATE	ISSUE/REVISION	APP
0	12/09/2021	ENF DRAWINGS	

SHEET NAME
EXISTING CONDITIONS SHEET 3 OF 3

SHEET NO.
V-103

FITZGERALD, JAMISON, B/W/working/HULL, MA, TOWN OF HULL 02045, 124 GROVE STREET, FRANKLIN, MA 02038, (774)277-6001, 4/26/2022

FITZGERALD, JAMISON, BIVINSKI/HULL, MA, TOWN OF HULL 1900027 Fitzpatrick Way Nantasket Ave Shoreline Protection/03_CADD/Design/Working/V-301 EXISTING SEAWALL SECTIONS.dwg - 4/26/2022

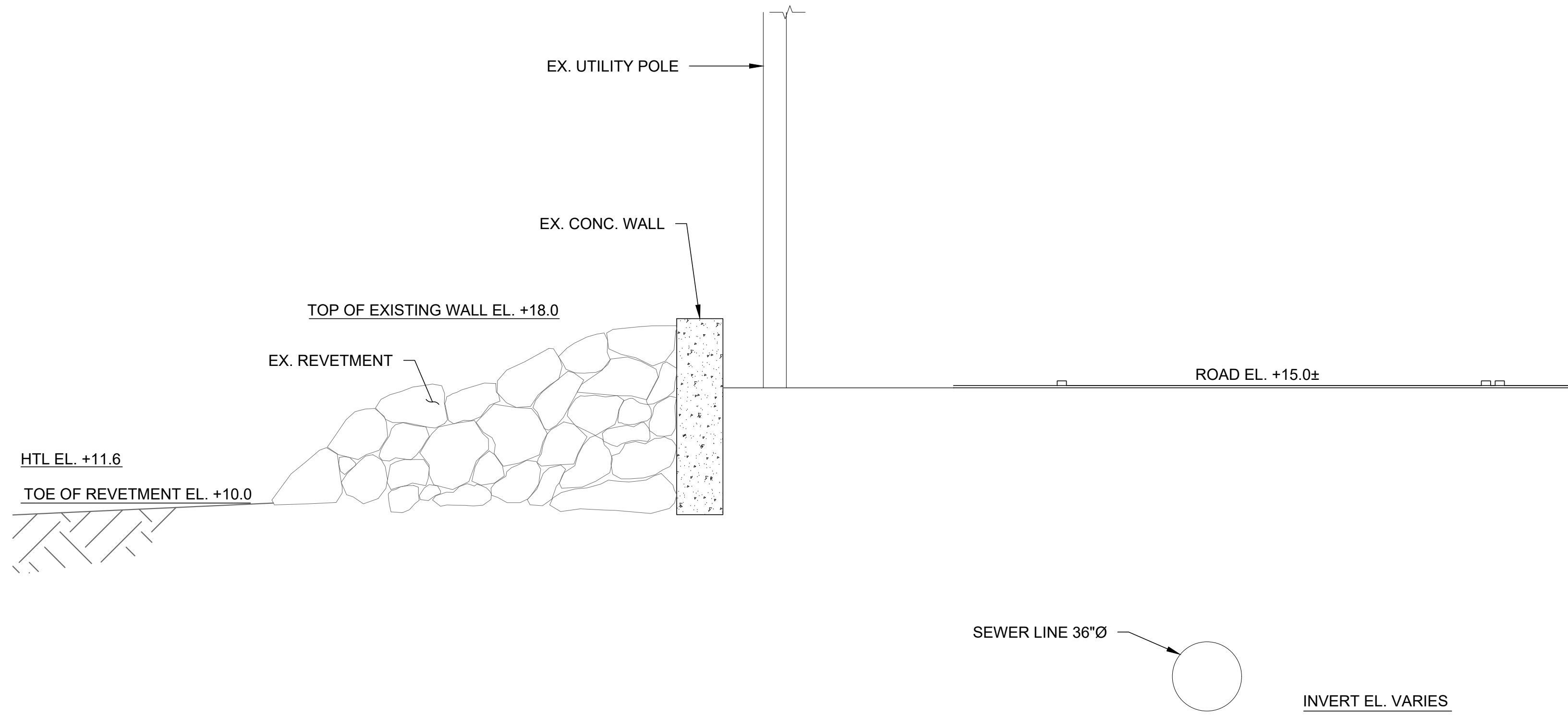

A SECTION
 V-111 EXISTING LOW WALL SCALE: 1/4"=1'-0"
 APPROX. STA 10+00 TO 13+15

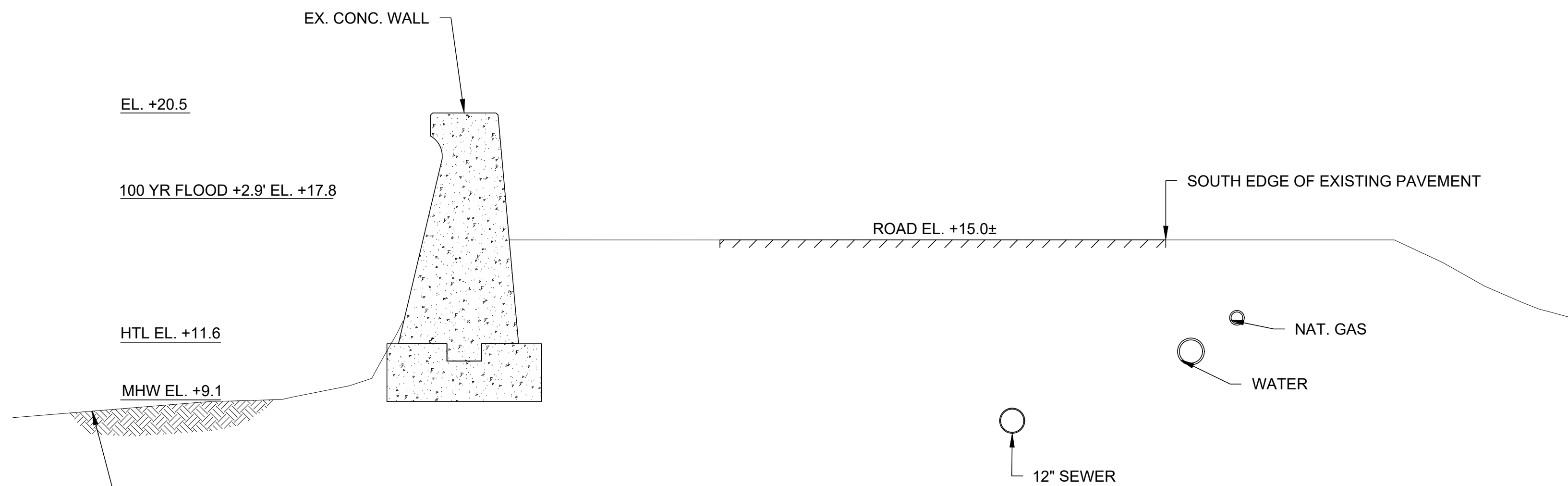

C SECTION
 V-111 EXISTING HIGH WALL SCALE: 1/4"=1'-0"
 V-112 APPROX. STA 13+15 TO 26+75
 V-113

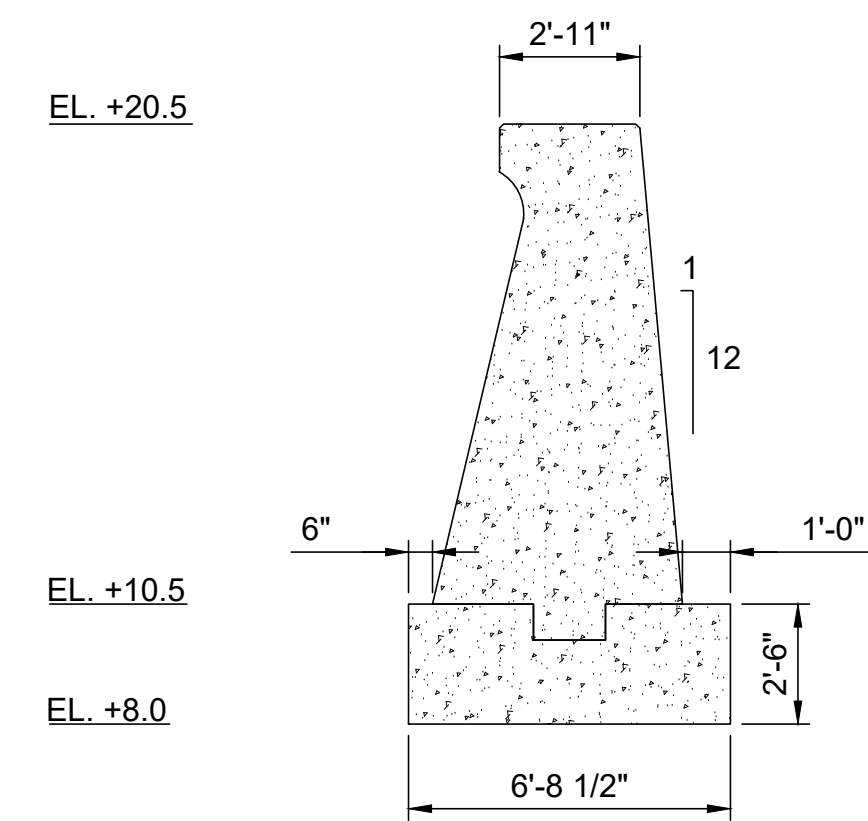

C SECTION (TYP)
 V-111 EXISTING HIGH WALL SCALE: 1/4"=1'-0"
 V-112
 V-113

FOR PERMITS ONLY
 NOT FOR CONSTRUCTION

TIDAL DATUMS	
HTL	+11.6
MHW	+ 9.1
NAVD88	+ 5.2
MLW	0.0



Attention:
 0 1"
 If this scale bar does not measure 1" then drawing is not original scale.



Designed: AJG
 Drawn: JSF
 Checked: RJT
 Approved: RJT
 P.E. No:
 GEI Project 1900027



TOWN OF HULL
 253 ATLANTIC AVE
 HULL, MA 02045

NANTASKET AVENUE SEAWALL

NANTASKET AVENUE
 HULL, MA 02045

NO	DATE	ISSUE/REVISION	APP
0	12/09/2021	ENF DRAWINGS	

SHEET NAME
EXISTING SEAWALL SECTIONS

SHEET NO.

V-301

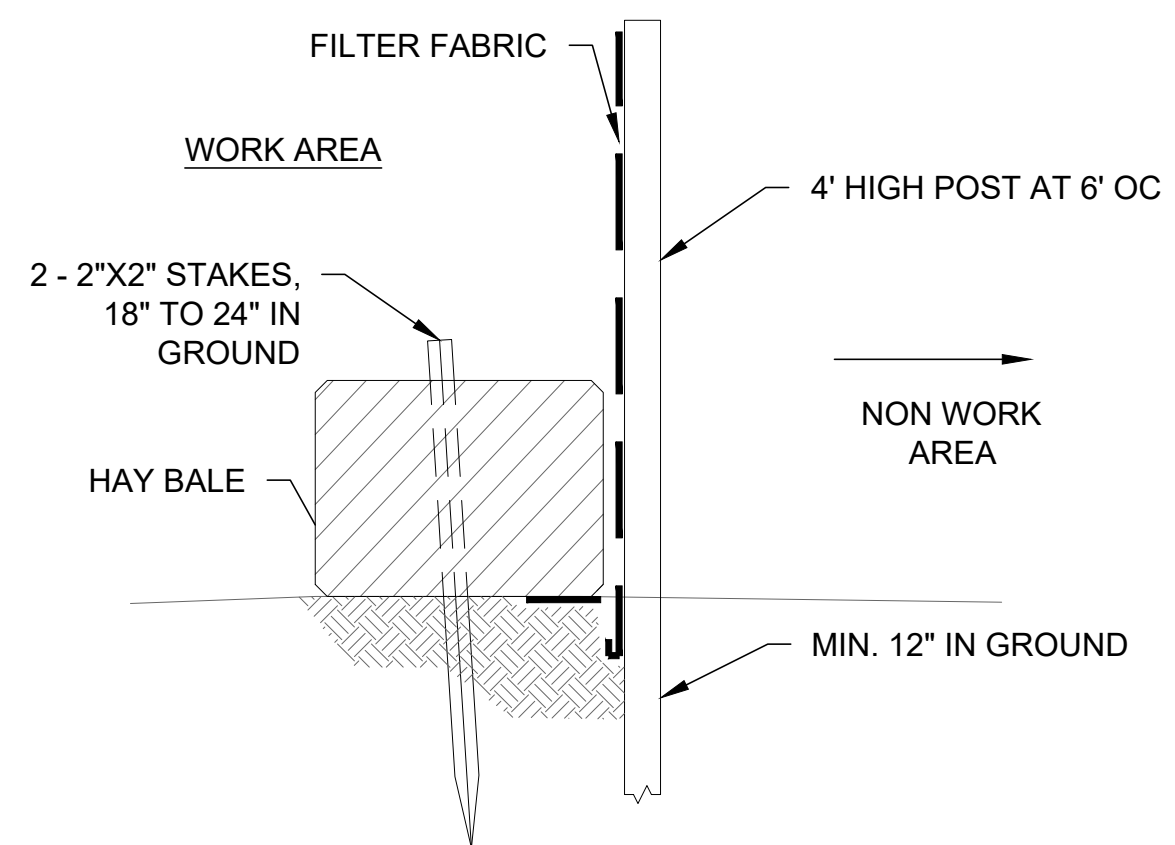
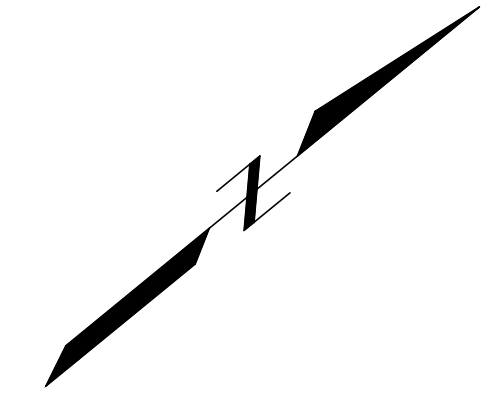
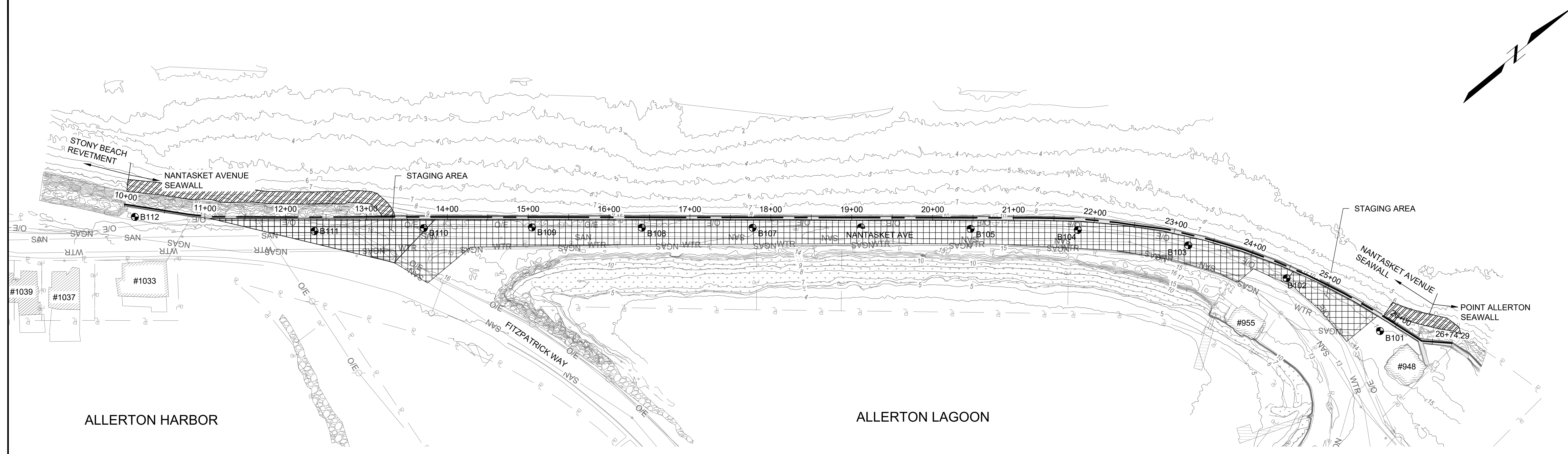

A DETAIL SILT FENCE (SF) SCALE: 3/4" = 1'-0"

- NOTES:
1. ALL WORK OUTSHORE OF EXISTING SEAWALL SHALL BE PERFORMED AT LOWER STAGES OF THE TIDE.
 2. CONTRACTOR SHALL MAINTAIN EXISTING SEAWALL FOR FULL LENGTH OF PROJECT UNTIL WORK OUTSHORE OF SEAWALL IS STARTED.
 3. ALL DEMOLITION OF SEAWALL TO BE FROM LANDSIDE OF PROJECT. CONTRACTOR SHALL REMOVE ALL FRAGMENTS FROM DEMOLITION OF SEAWALL.
 4. CONTRACTOR SHALL FULLY ENCIRCLE ROADWAY SIDE OF ALL DISTURBED AREAS WITH SILT FENCE AND HAY BALES. SILT FENCE AND HAY BALES SHALL CONNECT TO EXISTING SEAWALL AND FULLY ENCIRCLE THE DISTURBED AREA.
 5. ALL STOCKPILES OF MATERIAL SHALL BE FULLY SURROUNDED WITH SILT FENCE AND HAY BALES AND SHALL BE COVERED WHEN NOT IN USE.

LEGEND

- CONTRACTOR STAGING AREA
- TEMPORARY WORK ACCESS

FOR PERMITS ONLY
NOT FOR CONSTRUCTION

FITZGERALD, JAMISON, B. Working Hull, MA, TOWN OF HULL, MA, TOWN OF 1900027 Fitzpatrick Way Nantasket Ave Shoreline Protection CA-101 CONTRACTOR STAGING PLANS.dwg - 4/27/2022

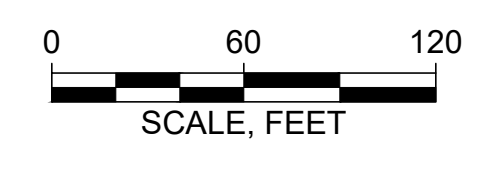

Attention:
0 1"
If this scale bar does not measure 1" then drawing is not original scale.



Designed: AJG
 Drawn: JSF
 Checked: RJT
 Approved: RJT
 P.E. No:
 GEI Project 1900027



TOWN OF HULL
 253 ATLANTIC AVE
 HULL, MA 02045

NANTASKET AVENUE SEAWALL

NANTASKET AVENUE
 HULL, MA 02045

NO	DATE	ISSUE/REVISION	APP
0			

SHEET NAME
CONTRACTOR STAGING PLANS

SHEET NO.
CA-101

FITZGERALD, JAMISON, B. Working in HULL, MA, TOWN OF 1900027 Fitzpatrick Way Nantasket Ave Shoreline Protection CD-301 DEMOLITION SECTIONS.dwg - 4/26/22

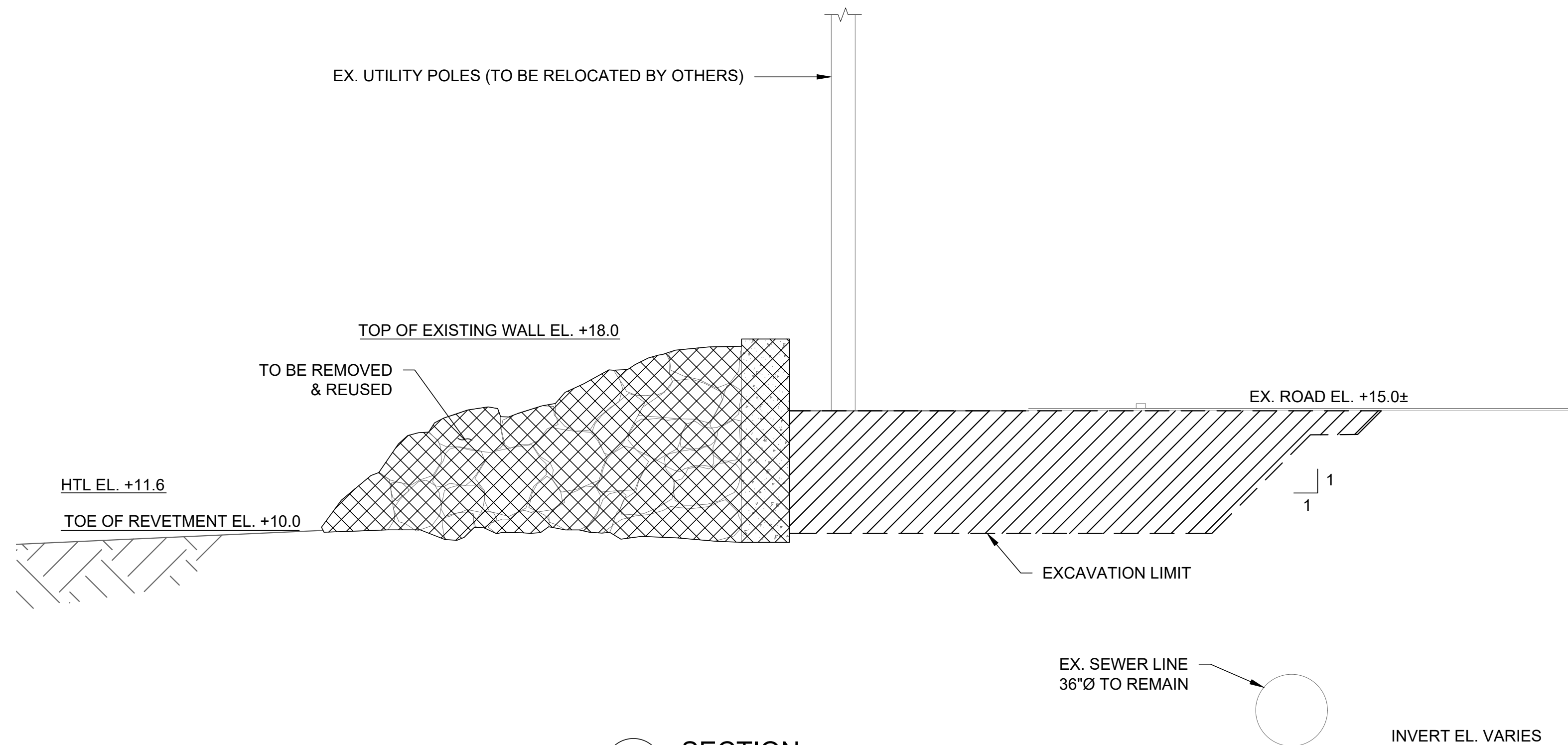

A SECTION
V-111 EXISTING LOW WALL SCALE: 1/4"=1'-0"

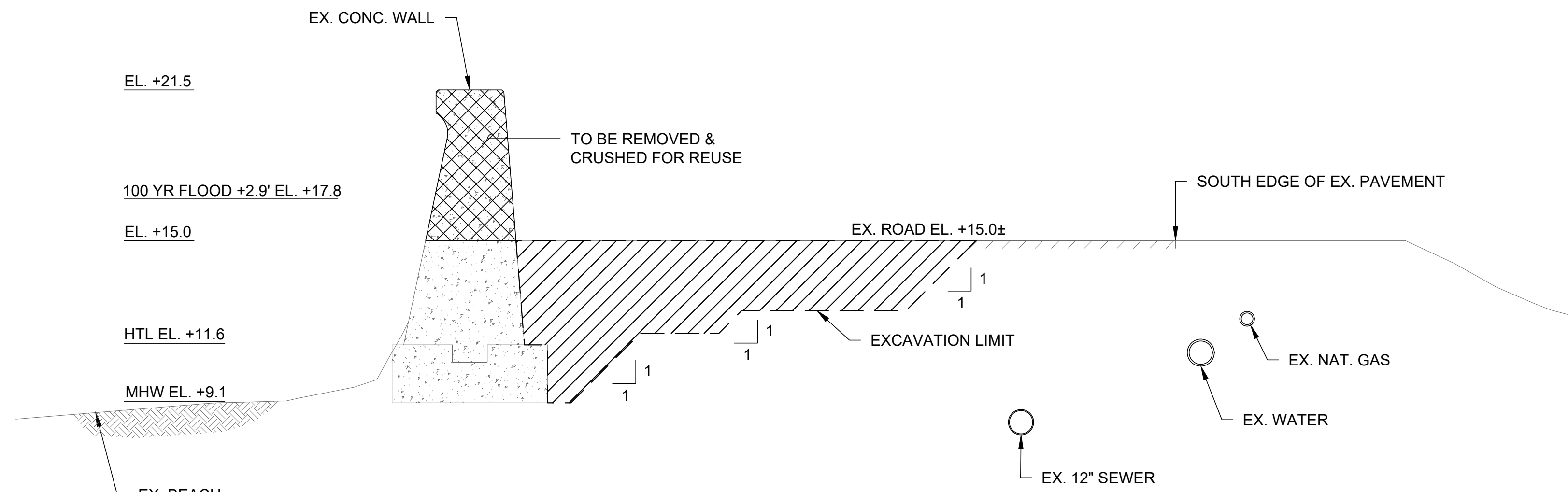

B SECTION
V-111 EXISTING LOW WALL SCALE: 1/4"=1'-0"
V-112
V-113

FOR PERMITS ONLY
NOT FOR CONSTRUCTION



Attention:
0 1"
If this scale bar does not measure 1" then drawing is not original scale.

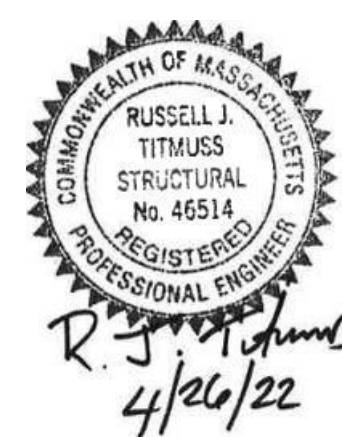

Designed: AJG
Drawn: JSF
Checked: RJT
Approved: RJT
P.E. No:
GEI Project 1900027



TOWN OF HULL
253 ATLANTIC AVE
HULL, MA 02045

NANTASKET AVENUE SEAWALL

NANTASKET AVENUE
HULL, MA 02045

NO	DATE	ISSUE/REVISION	APP
0			

SHEET NAME
DEMOLITION SECTIONS

SHEET NO.

CD-301

FITZGERALD, JAMISON, B. Working Hull, MA, TOWN OF HULL 1900027 Fitzpatrick Way Nantasket Ave Shoreline Protection CS-111 SEAWALL PLAN & ELEVATION - SHEET 1 OF 3.dwg - 4/26/2022

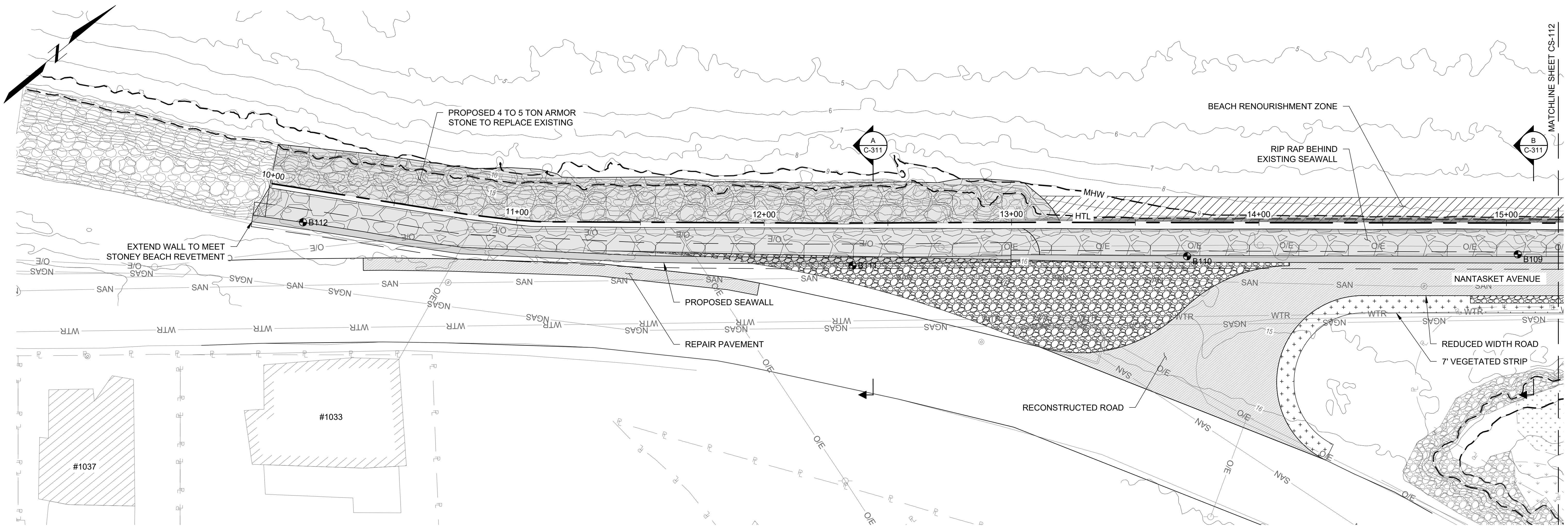

PROPOSED SEAWALL - PLAN
SCALE: 1"=20'-0"

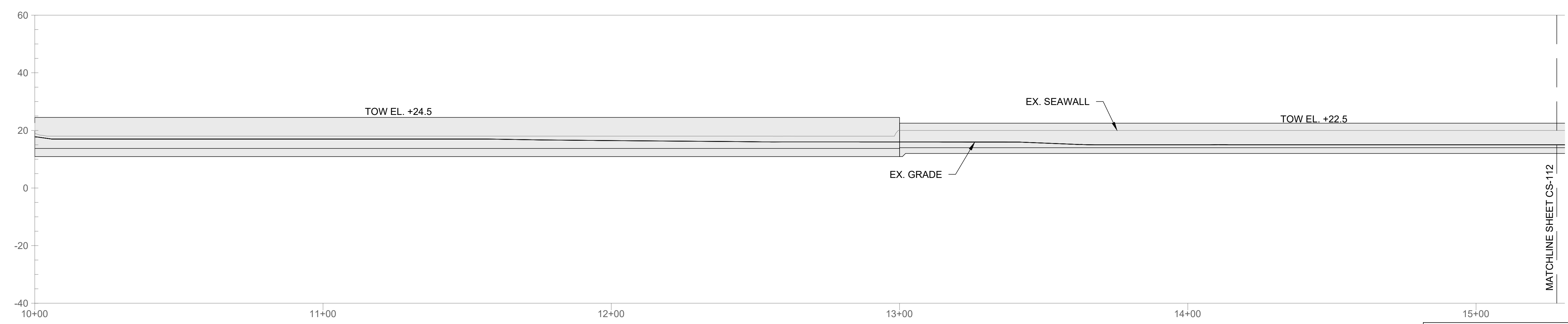

PROPOSED SEAWALL - ELEVATION
SCALE: 1"=20'-0"

FOR PERMITS ONLY
NOT FOR CONSTRUCTION

TIDAL DATUMS	
HTL	+11.6
MHW	+ 9.1
NAVD88	+ 5.2
MLW	0.0

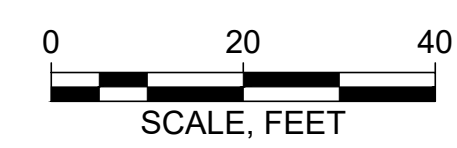

Attention:
0 1"
If this scale bar does not measure 1" then drawing is not original scale.

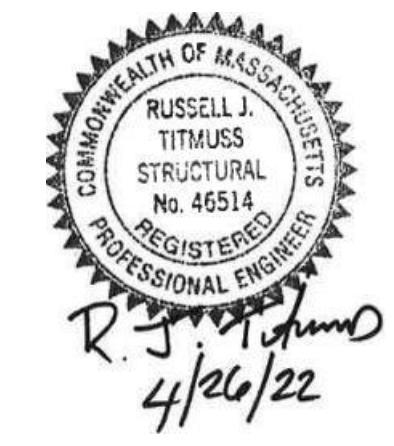

Designed:	AJG
Drawn:	JSF
Checked:	RJT
Approved:	RJT
P.E. No:	
GEI Project	1900027



TOWN OF HULL
253 ATLANTIC AVE
HULL, MA 02045

NANTASKET AVENUE SEAWALL

NANTASKET AVENUE
HULL, MA 02045

NO	DATE	ISSUE/REVISION	APP
0	12/09/2021	ENF DRAWINGS	

SHEET NAME
SEAWALL PLAN & ELEVATION - SHEET 1 OF 3

SHEET NO.
CS-111

FITZGERALD, JAMISON, B. Working Hull, MA, TOWN OF 1900027 Fitzpatrick Way Nantasket Ave Shoreline Protection CAD Design Working CS-112 SEAWALL PLAN & ELEVATION - SHEET 2 OF 3.dwg - 4/26/2022

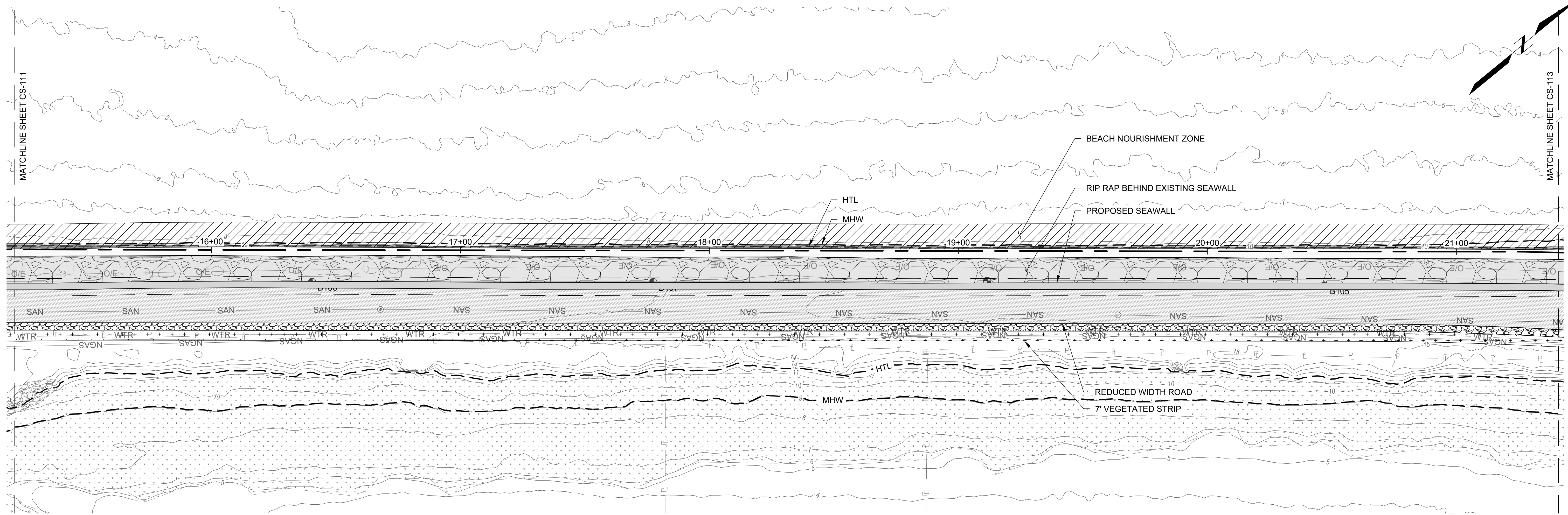

PROPOSED SEAWALL - PLAN
SCALE: 1"=20'-0"

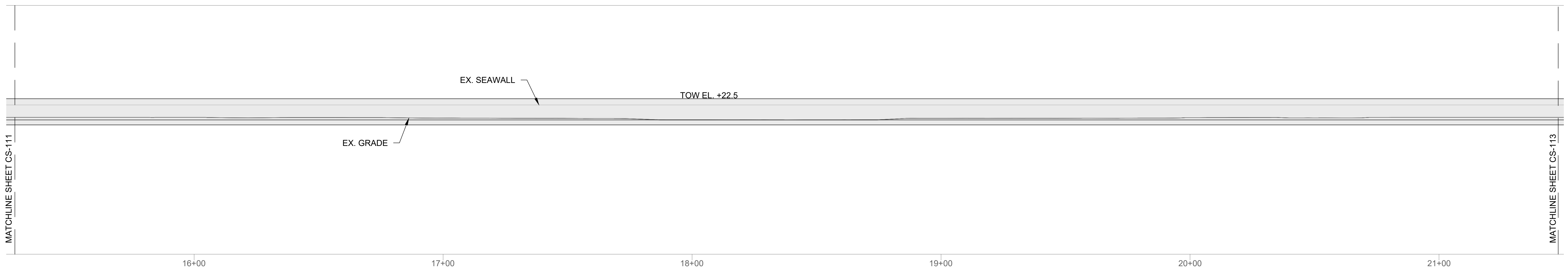

PROPOSED SEAWALL - ELEVATION
SCALE: 1"=20'-0"

FOR PERMITS ONLY
NOT FOR CONSTRUCTION

TIDAL DATUMS	
HTL	+11.6
MHW	+ 9.1
NAVD88	+ 5.2
MLW	0.0



Attention:
0 1"
If this scale bar does not measure 1" then drawing is not original scale.



Designed: AJG
Drawn: JSF
Checked: RJT
Approved: RJT
P.E. No:
GEI Project 1900027



TOWN OF HULL
253 ATLANTIC AVE
HULL, MA 02045

NANTASKET AVENUE SEAWALL

NANTASKET AVENUE
HULL, MA 02045

NO	DATE	ISSUE/REVISION	APP
0	12/09/2021	ENF DRAWINGS	

SHEET NAME
SEAWALL PLAN & ELEVATION - SHEET 2 OF 3

SHEET NO.
CS-112

FITZGERALD, JAMISON, B. W. Working Hull, MA, TOWN OF 1900027 Fitzpatrick Way Nantasket Ave Shoreline Protection CS-113 SEAWALL PLAN & ELEVATION - SHEET 3 OF 3.dwg - 4/26/2022

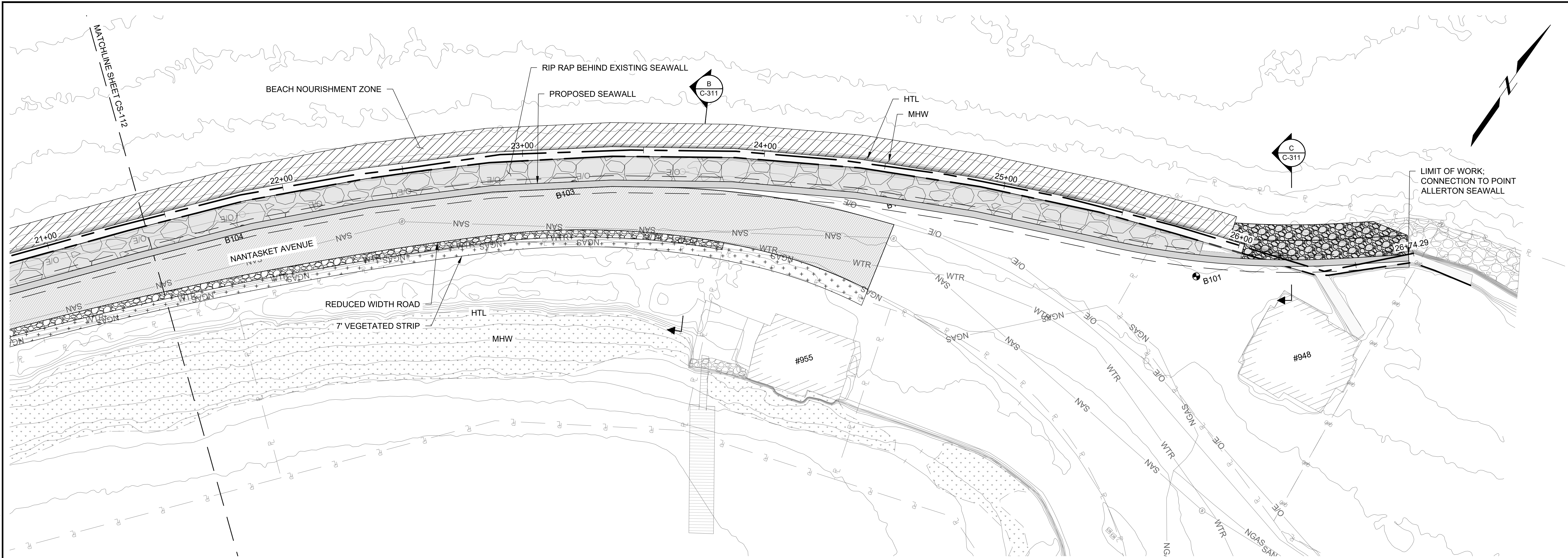

PROPOSED SEAWALL - PLAN
SCALE: 1"=20'-0"

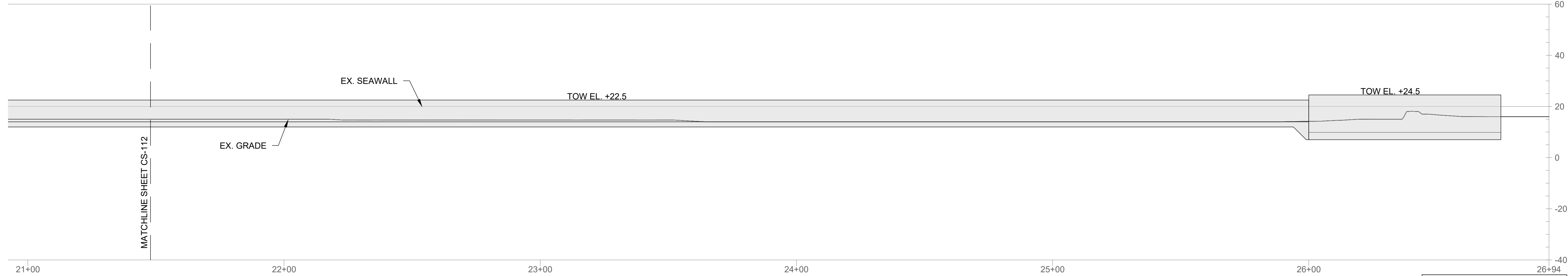

PROPOSED SEAWALL - ELEVATION
SCALE: 1"=20'-0"

FOR PERMITS ONLY
NOT FOR CONSTRUCTION

TIDAL DATUMS

HTL	+11.6
MHW	+ 9.1
NAVD88	+ 5.2
MLW	0.0

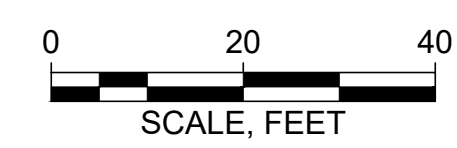

Attention:
0 1"
If this scale bar does not measure 1" then drawing is not original scale.

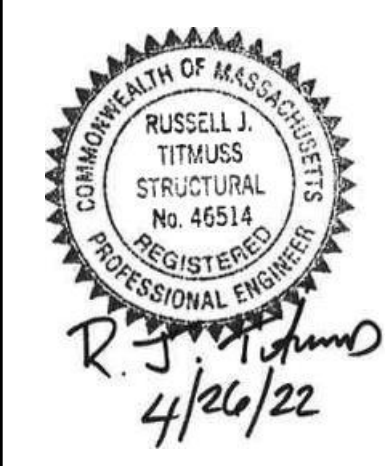

Designed:	AJG
Drawn:	JSF
Checked:	RJT
Approved:	RJT
P.E. No:	
GEI Project	1900027



TOWN OF HULL
253 ATLANTIC AVE
HULL, MA 02045

**NANTASKET AVENUE
SEAWALL**

NANTASKET AVENUE
HULL, MA 02045

NO	DATE	ISSUE/REVISION	APP
0	12/09/2021	ENF DRAWINGS	

SHEET NAME
**SEAWALL PLAN &
ELEVATION -
SHEET 3 OF 3**

SHEET NO.
CS-113

FITZGERALD, JAMISON, B. Working Hull, MA, TOWN OF 1900027 Fitzpatrick Way Nantasket Ave Shoreline Protection CS-311 SHORELINE SECTIONS SHEET 1 OF 2.dwg - 4/26/2022

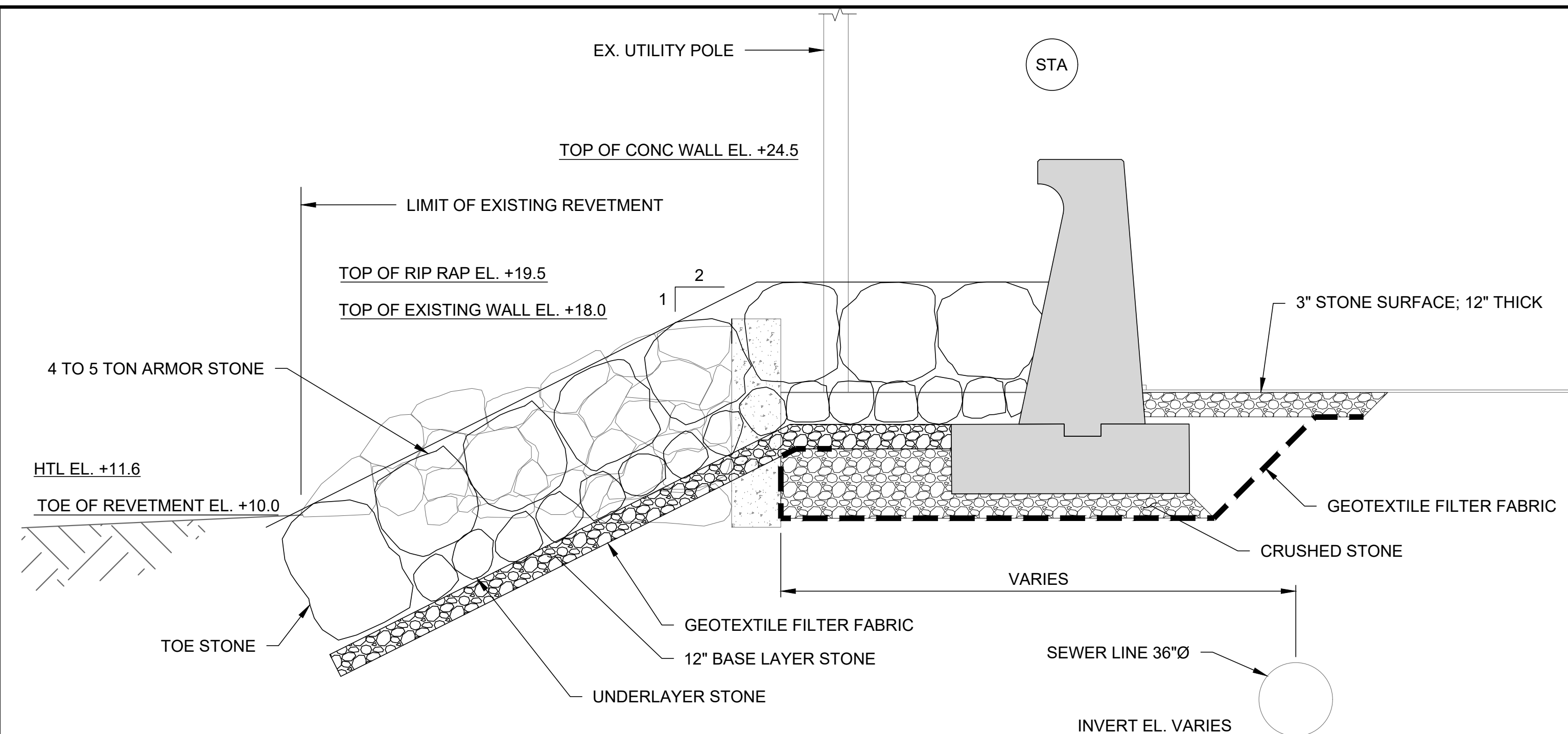

C SECTION
CS-111 PROPOSED WALL SCALE: 1/4"=1'-0"
 APPROX. STA 10+00 TO 13+15

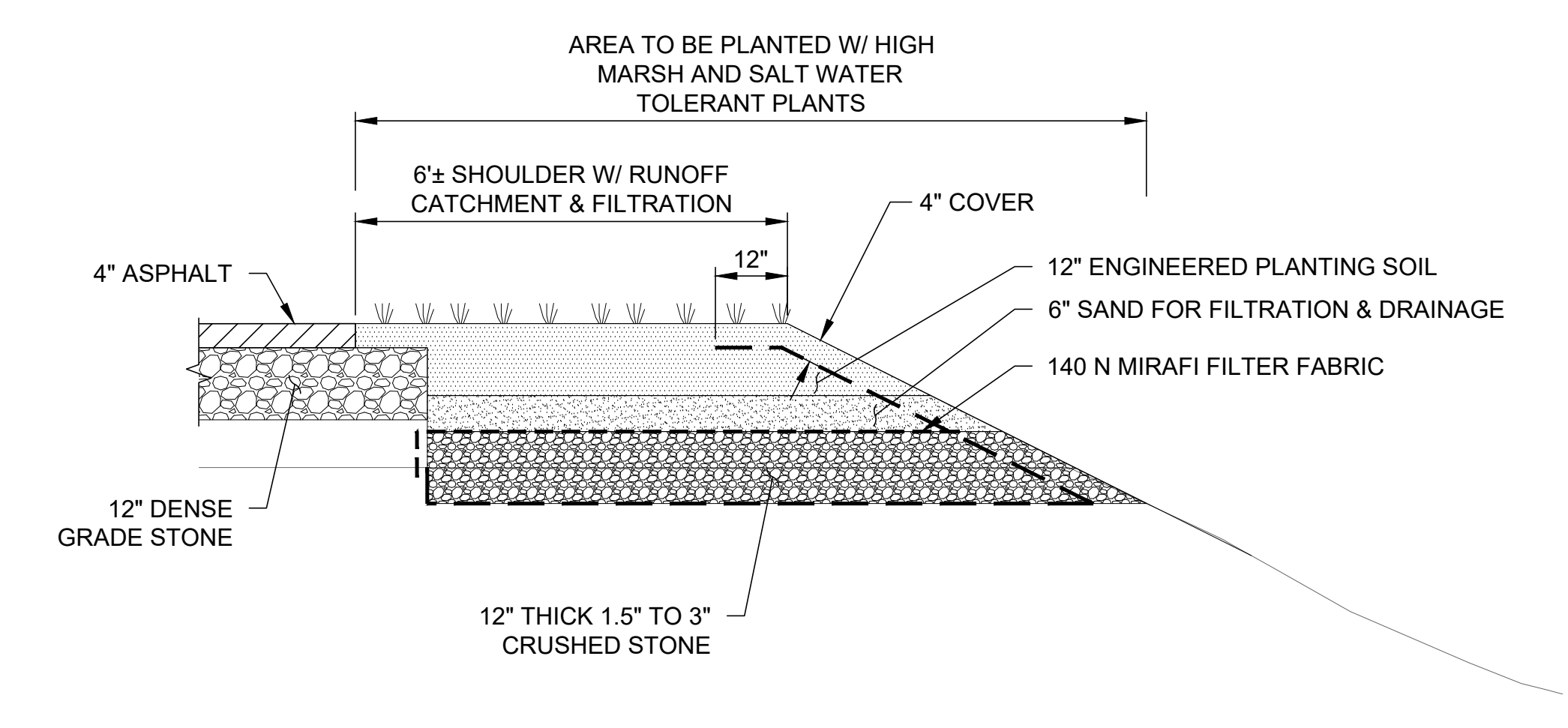

C SECTION
TYPICAL ROADWAY DRAINAGE FILTRATION SCALE: 1/2"=1'-0"

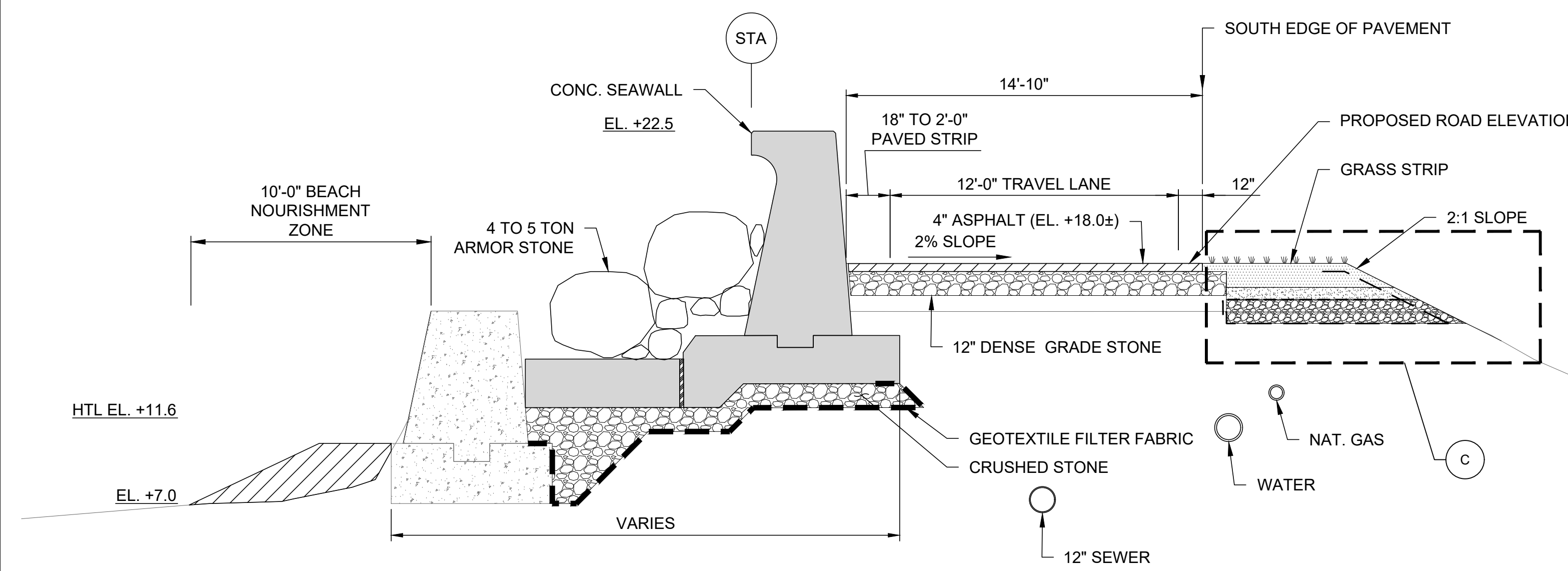

B SECTION (TYP)
C-111 PROPOSED WALL SCALE: 1/4"=1'-0"
C-112 APPROX. STA 13+15 TO 25+85
C-113

NOTE: BEACH NOURISHMENT MATERIAL TO MATCH EXISTING MATERIAL GRADING AND WILL ONLY BE PLACED IN ACCORDANCE WITH MONITORING PLAN.

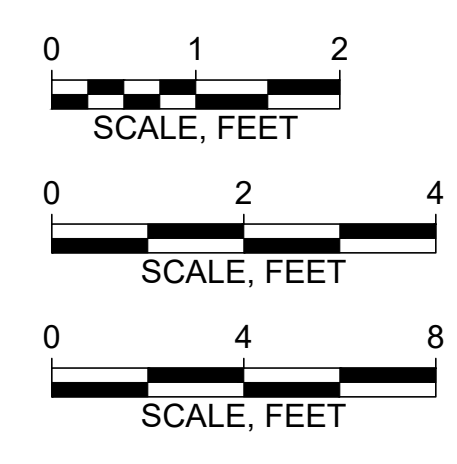

TIDAL DATUMS	
HTL	+11.6
MHW	+ 9.1
NAVD88	+ 5.2
MLW	0.0

Attention:

If this scale bar does not measure 1" then drawing is not original scale.

R. J. Titmuss
4/26/22

Designed:	AJG
Drawn:	JSF
Checked:	RJT
Approved:	RJT
P.E. No.:	
GEI Project	1900027

GEI Consultants
 GEI CONSULTANTS, INC.
 124 GROVE STREET
 FRANKLIN, MA 02038
 (774)277-6001

TOWN OF HULL
 253 ATLANTIC AVE
 HULL, MA 02045

NANTASKET AVENUE SEAWALL

NANTASKET AVENUE
 HULL, MA 02045

NO	DATE	ISSUE/REVISION	APP
0	12/09/2021	ENF DRAWINGS	

SHEET NAME
SHORELINE SECTIONS SHEET 1 OF 2

SHEET NO.
CS-311

FOR PERMITS ONLY
 NOT FOR CONSTRUCTION

FITZGERALD, JAMISON, B. W. W. HULL, MA, TOWN OF HULL 1900027, Fitzpatrick Way, Nantasket Ave, Shoreline Protection CS-312, SHORELINE SECTIONS SHEET 2 OF 2.dwg - 4/26/22

TOP OF CONC WALL EL. +24.5

TOP OF EXISTING WALL EL. +21.5

TOP OF RIP RAP EL. +17.0

HTL EL. +11.6

STA

EX. SEAWALL

GEOTEXTILE FILTER FABRIC

CRUSHED STONE

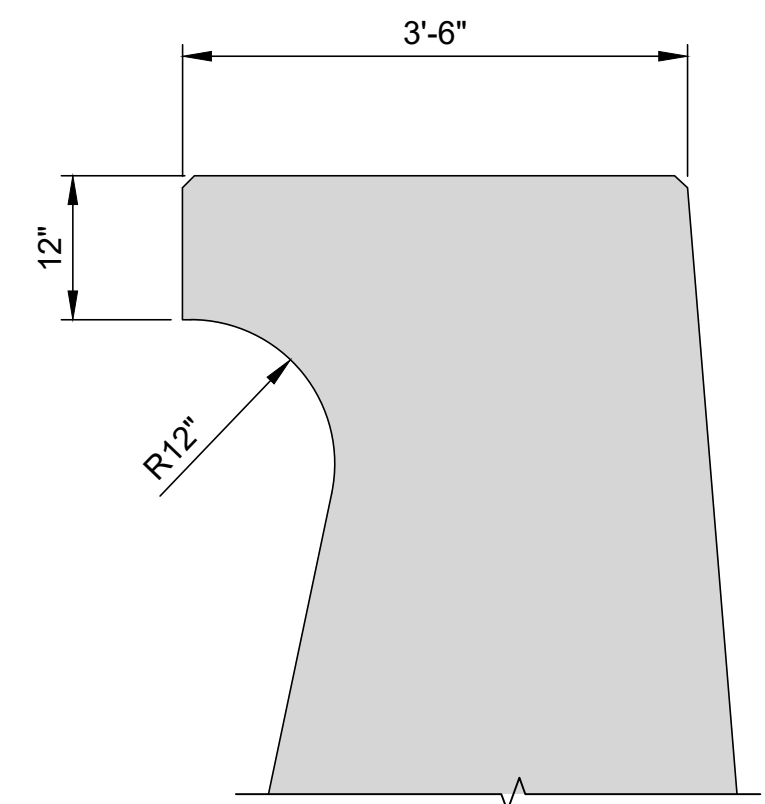

B DETAIL
WALL RECURVE SCALE: 3/4"=1'-0"

A SECTION
C-113 PROPOSED WALL SCALE: 1/4"=1'-0"
APPROX. STA 26+00 TO 26+75

TIDAL DATUMS	
HTL	+11.6
MHW	+ 9.1
NAVD88	+ 5.2
MLW	0.0

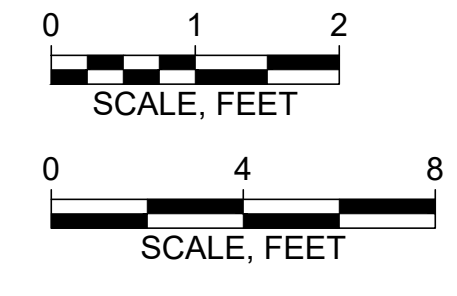

Attention:
0 1"
If this scale bar does not measure 1" then drawing is not original scale.



Designed:	AJG
Drawn:	JSF
Checked:	RJT
Approved:	RJT
P.E. No.:	
GEI Project	1900027



TOWN OF HULL
253 ATLANTIC AVE
HULL, MA 02045

NANTASKET AVENUE SEAWALL

NANTASKET AVENUE
HULL, MA 02045

NO	DATE	ISSUE/REVISION	APP
0			

SHEET NAME
SHORELINE SECTIONS SHEET 2 OF 2

SHEET NO.
CS-312

FOR PERMITS ONLY
NOT FOR CONSTRUCTION